

BEAUFORT WEST MUNICIPALITY

TARIFFS



2021/22

FEES AND RATES FOR SERVICE

A.

Item No

1.4 ABATTOIR: SEWERAGE RATES (from 1 July 2021)

An abattoir sewerage tariff in respect of private abattoirs is determined as follows to provide for the higher volume of water:

1. Grid well for catching water on slaughter floor, Beads and water room floor
R271.00

(Special Council: 31 May 2019: Item 8.3)

2. That where detritus traps need to be repaired or replaced, an additional tariff of R2 360.00 per month will be payable in respect of abattoirs.

(Council: 26 November 2002: Item 4.26)

1.6 ABATTOIR: DISPOSAL OF ABOTTOIR WASTE

The tariff for the dumping of abattoir waste by abattoir owners in the demarcated area is determined as follows from 1 July 1993:

Actual expense – total maximum slaughter units of abattoirs using the site: fees are payable monthly.

(Finance Committee: 1993.07.26: Item 19: Special Resolution)

(139th Amendment: June 2021)

A. (continue)

Item No

2. ADVERTISEMENTS
(See street Item S.8)

2.1 PURCHASE OR RENT OF MUNICIPAL LAND
Advertising deposit

R29.00

(Delegation of Forces L 1.1)

(Special Council: 19.6.2001: Item 12.1)

2.2 ADVERTISING COSTS: APPLICATION IN TERMS OF LAND USER ORDINANCE

(From 1 Junie 1994)

Together with application fees in terms of section 38 of Ordinance 15/85, an additional amount of R337.00 is payable, being the payment of advertising costs and advertising takes place in terms of Ordinance 15/85 after the above fees have been paid.

(Special Finance Committee: 1994.06.13: Item 6: Special Resolution)

(117th Amendment: May 2002)

B.

Item No.

2. BANNERS: TEAM FROM STREETS

See Streets as well as Delegation of Forces S 2.3)

2. A CEMETERY: FUNERAL FEES (from 1 July 2021)

The following fees are payable to the Council in advance in respect of funerals and service rendered in the Golden Acre cemeteries under the jurisdiction of the Council in accordance with the Standard Regulations.

(a) Premises fees

(i)	Single grave	R119.00
(ii)	For one person purchased after death bought for two people after death for simultaneous funeral	R119.00
(iii)	Reserved premises	R563.00
(iv)	Grave for stillborn baby or older person under 12 years	R119.00

(b) Fees in respect of digging of grave

(From 1 July 2021)

Ordinary grave in land: -

(i)	Persons 12 years old and older (6 ft)	R1 030.00
	Persons 12 years old and older (8 ft)	R1 244.00

Fees in respect of excavation and burial

(ii)	Persons under the age of 12 years and still born babies	R305.00
------	---	---------

(c) Excavations and Reburial

	Persons 12 years and older	R550.00
	Persons under the age of 12 and still born babies	R321.00

(Special Council: 15 June 2021)

(139Th Amendment: June 2021)

B. (continue)

Item No.

2. A	CEMETERY: FUNERAL FEES (continued)	
(d)	Reopening for two burials in single grave	R124.00
(e)	Extra depth for more than one person in the same grave	R90.00
(f)	Register and Office fees	
(i)	Certified extract from register	R13.00
(ii)	Certificate of transfer	R13.00
(iii)	Checking Register	R13.00
(iv)	Exchange of premises	R13.00
(g)	Purchase of Grave site	
(i)	Excavation-Excavation of Grave	R630.00
(ii)	Premises Additional	R269.00
	In the event of a person not being able to pay the fees in respect of the digging and closing of a grave as prescribed in these regulations, he is allowed to dig and close a grave himself under the supervision of an official of the Council. However, the fees for premises as prescribed in the regulations are still payable	
(iii)	If a funeral is held on a Saturday, Sunday and Public Holiday is an additional amount of payable.	R40.00
	(P.K. 1097/1970)	
(h)	Issuance of a permit for the erection of a tombstone	R25.00
(i)	Opening of grave: Blyth Street Cemetery	
	1. The following deposit are charged in respect of burial in the cemeteries located on Blyth Street and such deposits are forfeited if graves are not made up within 12 months after funerals.	
	Graves for adults	R239.00
	Graves for children	R239.00

2. That the Cemetery on Blyth Street be extended to the east and that this section be reserved for funerals where the erection of a grave is not planned and that no deposits are charged in the relevant section.

(Special Council: 19 June 2001: Item 12.1)

3. That approval be granted that the period as permitted for the erection of graves be extended to 24 months before the deposit is forfeited.

(Council: 1999.04.26: Item 19.15)

(139th Amendment: June 2021)

A. (continue)

Item No.

2. B CEMETERY: WALL OF MEMORIES (from 1 July 2021)

Cost per Nis R630.00
(Council: 15 June 2021)

2. C DRY RIVER CEMETERY: FUNERAL FEES

The tariff in respect of a single grave in respect of the Dry River Cemetery was Determined as follows:

(a) For one person after death R198.00
(b) For two persons after death for simultaneous burial R198.00

The rest of the rates applicable to the Blyth Street Cemetery also apply to the Dry River Cemetery.

(Council: 15 June 2021)

2. D CEMETERY: TOMB PLACES: INDICATION OF: FREE GROUNDS

Designation of grave sites at Municipal freeholds R20.00 / event

(Council: 15 June 2021)

2. E CEMETERY: DESIGNATION OF GRAVE: (from 1 July 2021)

A deposit of R95.00 will be charged with the allocation of a grave site and the deposit will be refundable after the grave has been dug and inspected by the City Engineer.

(Council: 15 June 2021)

2. F CEMETERY: MERWEVILLE

Kerkhof	R70.00	Single
Kerkhof	R139.00	Dubble

(Council: 15 June 2021)

(139th Amendment: June 2021)

CEMETERIES

RATES FROM 1 JULY 2021

Reservations	R351.00
Permit for tombstone	R25.00
Nis: Wall of Remembrance	R632.00

TOMB PLACES

GRAVE PREMISES F/G/H/ : 6 VT		GRAVE PREMISES F/G/H/ : 8 VT	
Premises	R119.00	Premises	R119.00
Digging a grave	R907.00	Digging of Grave	R1124.00
Clearance deposit	R123.00	Clearance Deposit	R123.00
Point of deposit	<u>R95.00</u>	Point of Deposit	<u>R95.00</u>
TOTAL	R1244.00	TOTAL	R1461.00
GRAVE PREMISES A/B/C/D/J: 6 VT		GRAVE PREMISES A/B/C/D/J8 VT	
Premises	R119.00	Premises	R119.00
Digging of Grave	R907.00	Digging of grave	R1124.00
Clearance deposit	R123.00	Clearance deposit	R123.00
Point of Deposit	<u>R95.00</u>	Point of Deposit	<u>R95.00</u>
Tombstone Deposit	<u>R239.00</u>	Tombstone deposit	<u>R239.00</u>
TOTAL	R1483.00	TOTAL	R1700.00
CHILDRE GRAVE :UNDER 9 YEARS		EXCAVATED / REBURIAL	
MATES		12 Years and older	R550.00
Premises	R119.00	Under 12 yr	R321.00
Digging of grave	R187.00		
Clearance deposit	R123.00		
Point of deposit	<u>R95.00</u>		
Tombstone deposito	<u>R239.00</u>		
TOTAL	R763.00		

PLEASE NOTE:

Point of deposit refundable as soon as official confirms that right is buried.

Tombstone deposit refundable once tombstone has been erected within 2 years after burial.

T.

Item No.

4. TAXES

4.1a General: 1 July 2021 to 30 June 2022

Beaufort West, Merweville, Nelspoort, Murraysburg

(i)	Residential	R0.020066
(ii)	Business	R0.028092
(iii)	Industrial	R0.028092
(iv)	Public Service properties	R0.028092
(v)	PSI	R0
(vi)	National Monuments	R0.028092 min 10% add. Discount
(vii)	Agricultural	R0.005017
(viii)	Multiple use	as per allocation
(ix)	Municipal	R0
(x)	Nature Reserve	R0
(xi)	Vacant Land	R0.024079

(Council: 15 June 2021)

4.2A A tax rebate granted to homeowners of either single dwelling properties or who own more than one dwelling or who own a semi-detached house, provided that:

- (i) That they must occupy the property themselves
- (ii) That only a rebate is granted on one dwelling or the part the part of the link house they occupied themselves
- (iii) Be above the age of 60 years
- (iv) Not a total income derived from other sources (including a monthly income of the other half of the owner) as set out below:

R1 890 and under	30%
R1 891 to R3 780	20%
R3 781 to R7 500	10%

The said discounts will only apply if the Municipal valuation of the dwelling in question is less than R750 000.

The said discount is also granted to persons receiving Welfare / Disability Grants.

4.2B ALL RESIDENTIAL PROPERTIES

Exempt from tax on first R19 000 of market value

(139th Amendment: June 2021)

T. (continue)

Item No.

- 4.3 That the 10% tax rebate be granted to owners of National Monuments, provided that the rebate will only be granted if the building is in a satisfactory condition and that during the second month of each tax year, the City Engineer, submit a report on such buildings on the condition thereof for consideration by the Council for the granting of a tax rebate, or not.

(Council: 31 May 2016: Item 8.5)

- 4.4 That the following tariff be charged where an owner requests a supplementary valuation in terms of section 11 (2) (a) of the Property Valuation Ordinance, 1993.

1. Travel expenses at R2.26 per km, plus
2. Valuation fees of R2 003.00

(Special Council: 28 May 2002: Item 1.2)

5. AVAILABILITY FEES

(By-Law regarding the levy of availability fees: PK 1209 of 15.12.1977)

5.1 POLICY

5.1.1 Accessibility fees on undeveloped ERF'S 200 m and larger are charged only where the service is available, where the erf borders a street front and where there is a sufficient street front to place a building.

5.1.2 When the electricity or water supply to an erf is shut off for any reason and thus remains close for a continuous period of six months, availability fees are charged from the first day of the month immediately following the expiry of the six months.

5.1.3 In the event that the owner of an erf who pays the basic minimum fee is subsequently provided with a connection to the water or electricity supply, the availability fee ceases from the commencement of the ordinary service fee.

5.1.4 The City Engineer is authorized to charge availability fees in accordance with the provision of the applicable by-law and taking into account existing policies of the Council.

(117th Amendment: May 2002)

T. (continue)

Item No.

5.1.5 The fees payable to the Council on a monthly basis by the owner of any property that is not connected to the electricity or water supply as well as the sewerage network of the Council, but which in the opinion of the Council can reasonably be connected in this way, as well as owners of prepaid meters who does not buy water is determined by the Council by Special Resolution.

(Finance Committee 2332/1.9 of 27 June 1984)

TARIFF (from 1 July 2021)

- | | | |
|-------|-------------|---------------------------------|
| (i) | Electricity | R307.01 per erf per month |
| (ii) | Water | R172.61 per month Beaufort West |
| (iii) | Water | R27.91 per month Merweville |
| (iv) | Sanitation | R131.12 per month Beaufort West |

(Council: 15 June 2021)

(139th Amendment: June 2021)

B. (continue)

Item No.

6. LIBRARIES

A. In terms of Standard Library By-Law PK 260/1969, as amended, PK 109/1978

Duplicate tickets: (Art 296)(b))	R0.05
Discussion of library material: (Art 4)	R0.05
Preservation of library material: Art 3(5)(a))	R0.12
Information Library: Cape Town: Per call	R5.60

(Special Council: 1998.06.15: Item 2)

Rental of Library Hall

(a) Non-profit institutions and persons / institutions from outside the town's boundaries:
R156.00 per event

From 1 July 2021

(b) Cultural organizations and other non-profit institutions. (Voëlklub etc.): R50.00 per event

(c) Church (church purposes): R59.00 per event

(d) Creches and other school: Free

(e) Rental of kitchen: Mimososa Library

R106.00 per event from 1 July 2021

(Council: 15 June 2021)

(137th Amendment: Council 31 May 2019)

B. (continue)

Item No.

B. In terms of Standard Library By-Law: PK 640/1990: 12 October 1990

Article 3(2)(b):

A person who resides in the area of jurisdiction of the local authority for less than three months may register as a visitor if: -

(b) He/She deposits with the Librarian the deposit determined by the relevant local authority from time to time, and R34.00 per item

(Special Council: 19.6.2001: Item 12.1)

Article 7(1)(a) and 71(1)(b)

A fine for the preservation of library material after the period specified in these by-laws is charged in respect of: -

(a) Library material other than films and videos at a rate set by the local authority, but not exceeding the maximum set by the Director from time to time for a week or part of a week longer than such period, or

(b) Films and videos at a daily rate determined by the Director from time to time.

For the above: The maximum fee as determined by the Director

(Finance Committee: 1990.10.22: Item 33)

(c) Photocopy prints

R3.00 for A4 size copy; and

R4.00 for A3 size copy.

(Council: 15 June 2021)

(139th Amendment: June 2021)

B. (continue)

Item No.

C INCREASE OF LIBRARY FINES

1. That the following library fines be levied with effect from 18 September 2000: -

Lost borrower bags: R2.00 per bag

All material (Video's included)

R1.00 per week or part thereof with a total maximum fine of R17.00.

Video's: R2.00 per day or part of a day that the item is late.

Booking of library material: maximum of R3.00 per item.

(Standing Committee: Tourism et al: 18 September 2000: Item 4)

(123rd Amendment: June 2006)

B. (continue)

Item No.

7. BUILDING PLANS

7.1 Exemption fees: (from 1 July 2021)

	Research fee	Clearance deposit
Minimum fee (any fence, pool and internal changes included)	R240.00	R356.00
0 tot 100 m ²	R18.00 / m ²	R25.00 / m ²
101 tot 200 m ²	R14.00 / m ²	R21.00 / m ²
201 tot 1 000m ²	R10.00 / m ²	R17.00 / m ²
1001 tot ∞ m ²	R2.00 / m ²	R4.00 / m ²
Maximum fee	R13 030.00	R21 885.00
Advertising sign	R226.00	R0.00

(Council: 15 June 2021)

7.2 Late submission of building plans: (from 1 July 2021)

If a building plan is submitted for the erection of a building after such building has already been erected or is in the process of erection, or if construction work is commenced before the plan has been approved in this regard by the local authority, a fine equal to four times the amount prescribed in respect of such plan must be paid, provided that the minimum penalty fine in respect of each building plan is R236.00 and the maximum fine of each such plan is R1 155.00, in addition to the ordinary fees as in 7.1 above.

(Council: 15 June 2021)

7.3 Making available list of approved building plans: from 1 July 2021

A tariff of R88.00 has been set for making the monthly list of approved building plans available to the public.

(Council: 15 June 2021)

(139th Amendment: June 2021)

B. (continue)

Item No.

8. FIRE RESCUE

(Regulations PK 396/1982 and 756/1982)

Tariff

8.1 That the remuneration of temporary fire brigade personnel be determined as follows: -

8.1.1 Assistance service is paid in terms of the Basic Terms of Service of SAMWV with a minimum daily rate of R8.75.

8.1.2 A fixed amount of 89.00 per call is paid to each serving member of the fire brigade staff regardless of whether it takes place within or outside working hours.

8.1.3 Overtime for service after hours is paid according to each member's basic remuneration on the following basis:

(a) Monday to Saturday: time and a half, Sunday: Double time

(b) Over time is calculated per full hour regardless of whether only half an hour is worked.

(c) Remuneration per exercise R27.00 per occasion

(Spec Council: 1999.06.07: Item 2)

8.2 Fire Rescue cost per call out

Fire Rescue Brigade

R500.00 per opportunity

Water truck Municipal Area

R371.00 per opportunity

Water truck outside Residential Area

R247.00 per opportunity

(Special Council: 2000.05.30: Item 4)

8.3 Operation Costs for Fire Brigade

Fire Brigade

R310.00/Hour or part of

Water truck

R78.00/Hour or part of

Kilometer rate outside Municipal area

R3.00/km/Vehicle

Fire Extinguisher

R217.00/opportunity

Foam

R37.00 per liter

(Spec Council: 2000.05.30: Item 4)

(111th Amendment: May 2000)

B. (continue)

Item No.

8.4 Discount

Where proof of income can be provided and insurance is out of the question, the following rebate can be granted: -

0 – 1050 p.m.	80%
1050 – 1600 p.m.	60%
1601 – 2700 p.m.	40%
2701 – 3200 p.m.	20%

(Spec Council: 2000.05.30: Item 4)

(111th Amendment: May 2000)

D.

Item No

1. ANIMALS

1.1 Continuation on Village Land

See withdrawal Item 5

1.2 Removal of dead animals: (from 1 July 2021)

Cattle, horse, donkey, mule, pig / opportunity

R250.00

Sheep, goat / opportunity

R125.00

(Council: 15 June 2021)

(139th Amendment: June 2021)

D.

Item No

2. VILLAGE LAND

2.1 Circus per day R500.00
(On site as determined by Council) Service included

Inspection fee in respect of the above R90.00

On site in private R90.00

(Council: 15 June 2021)

2.2 Site for accommodation of temporary work teams of Contractor on site as determined by Council

2.3 The site at the soccer field in Newtown is made available for a circus (See 3.1)

2.4 The contractors must install a wire mesh fence at least 1.5 m high around the site they are renting.

2.5 Contractors must arrange with the Head: Health Service and Cleaning regarding the installation of bucket facilities at their own expense and accept responsibility for the cost of removal.

2.6 Domestic water connections are provided at the rate laid down and water consumption is paid at the existing rate.

3. TOWN LAND: REMOVAL OF:

(From 1 July 2021): VAT included

Sand per m ³	With a minimum	R65.00	R65.00
Soil per m ³	With a minimum	R65.00	R65.00
Gravel per m ³	With a minimum	R106.00	R106.00
Flat stone per m ³	With a minimum	R65.00	R65.00

(Council: 15 June 2021)

(139th Amendment: June 2021)

D.

Item No

4. DRAINING AND SEWERAGE

(See Sewerage: Item R2)

5. MISCELLANEOUS: LAND AND GROUND: PROPERTY TRANSACTIONS: PRINTS OF LIST OF TRANSPORTERS

A4 sheet of return with transfers of real property located in Beaufort West Municipal area and registered in the Deeds Office in Cape Town including all financial institutions and building societies available on request: -

R33.00 per sheet

(Council: 15 June 2021)

(139th Amendment: June 2021)

E.

Item No

	BEAUFORT WEST MUNICIPALITY ELECTRICITY TARIFFS FOR THE FINANCIAL YEAR 2021 - 2022	2021/22	2021/22
	ELECTRICITY TARIFFS: (From 1 July 2020) All prices VAT Excluded	Seasonal Demand High	Seasonal Demand Low
1.1	Tariff 1.1: Domestic Credit & Prepaid => 20 Amp (1 & 3 Phase) Basic charge/month Per 5 Amp Charge/month (minimum 25 Amp) Energy charge (cent/kWh)	R212.97 R49.41 218.96	R212.97 R49.41 151.28
1.2	Tariff 1.2: Domestic Indigent Prepaid (Maximum 20 Amp) Basic charge/month Energy charge (cent/kWh)	None 182.09	None 173.10
1.2A	Tariff 1.2A: Domestic Prepaid <= 20 Amp (Maximum 20 Amp) Basic charge/month Energy charge (cent/kWh)	None 276.54	None 250.69
2.1	Tariff 2.1: Maximum Demand User LV Basic charge/month Maximum demand/kVA/month (Minimum 25 kVA) Notified demand/kVA/month (Notified by customer) Energy charge (cent/kWh)	R1283.11 R162.52 R121.94 173.05	R1283.11 R162.52 R121.94 108.06
2.1A	Tariff 2.1A: Maximum Demand User MV Basic charge/month Maximum demand/kVA/month (Minimum 25 kVA) Notified demand/kVA/month (Notified by customer) Energy charge (cent/kWh)	R3268.71 R149.95 R112.45 159.68	R3268.71 R149.95 R112.45 99.70
2.2	Tariff 2.2: Small Commercial & Ind. Credit & Prepaid => 20 Amp (1 & 3 Phase) Basic charge/month Per 5 Amp Charge/month (Minimum 25 Amp) Energy charge (cent/kWh)	R517.09 R114.27 193.67	R517.09 R114.27 154.65

2.2B	Tariff 2.2B: Small Commercial Prepaid = 20 Amp (Maximum 20 Amp) Including Sport Organizations		
	Basic charge/month	None	None
	Energy charge (cent/kWh)	301.22	273.64
4.1	Tariff 4.1: All Public Lights (Municipal & Private)		
	Maintenance charge per luminaire/month ≤ 150 WATT	R99.43	R99.43
	Maintenance charge per luminaire/month > 150 WATT	R119.67	R119.67
	Energy charge (cent/kWh)	239.99	174.84
6.	Tariff 6: Availability Fees		
	Electricity availability fee per vacant stand/month	R307.01	R307.01
7.	Tariff 7: Domestic Time of Use (1 & 3 Phase)		
	Basic charge/month	R215.85	R215.85
	Per 5 Amp charge/month (Minimum 15 Amp)	R50.09	R50.09
	Energy charge Peak (cent/kWh)	450.56	159.45
	Energy charge Standard (cent/kWh)	149.40	115.53
	Energy charge Off-peak (cent/kWh)	89.62	80.06
7.1	Tariff 7.1: Commercial Time of Use (1 & 3 Phase)		
	Basic charge/month	R547.60	R547.60
	Per 5 Amp charge/month (Minimum 15 Amp)	R111.19	R111.19
	Energy charge Peak (cent/kWh)	450.56	159.45
	Energy charge Standard (cent/kWh)	149.40	115.53
	Energy charge Off-peak (cent/kWh)	89.62	80.06
8.	Tariff 8: Unmetered Usage (Telkom Towers)		
	Basic charge/month	R2197.26	R2197.26
	Energy charge (cent/kWh)	None	None
9.	Tariff 9: Green Energy (Solar or Wind) Sold to the Municipality		
	Basic charge/month	R120.38	R120.38
	Export Energy charge Peak (cent/kWh)	355.06	115.82
	Export energy charge Standard (cent/kWh)	107.54	79.71
	Export energy charge Off-peak (cent/kWh)	58.42	50.56
10.1	Tariff 10.1: Large MV (11-22 kV) Time of Use		
	Basic charge/month	R4969.50	R4969.50
	Maximum demand/kVA/month (Minimum 100 kVA)	R142.25	R142.25
	Notified demand/kVA/month (Notified by customer)	R106.67	R106.67

	Reactive energy charge (cent/kVARh)	4.21	4.21
	Energy charge Peak (cent/kWh)	432.42	156.20
	Energy charge Standard (cent/kWh)	146.66	114.52
	Energy charge Off-peak (cent/kWh)	99.36	80.85
10.2	Tariff 10.2: Large LV (400 Volt) Time of Use		
	Basic charge/month	R1 489.56	R1489.56
	Maximum demand/kVA/month (Minimum 100 kVA)	R152.12	R152.12
	Notified demand/kVA/month (Notified by customer)	R114.13	R114.13
	Reactive energy charge (cent/kVARh)	4.21	4.21
	Energy charge Peak (cent/kWh)	453.01	163.63
	Energy charge Standard (cent/kWh)	153.64	119.98
	Energy charge Off-peak (cent/kWh)	104.09	84.70

E (continue)

Item No

1.2.3.1 SERVICE CONNECTIONS

The following fees are payable to the Council with effect from 1 July 2021 in respect of three-phases or single phase underground service connections.

- (i) Where the power supply to a premise is provided with only one consumer, R24 210 for a three-phase connection and R22 310 for a single-phase connection excluding VAT, provided that where special equipment or heavier conductors require or require 10mm is deemed. Or where another route is required longer than determined by the Electrotechnical Engineer, the full cost such connection is recovered from the applicant based on actual cost of materials, up to a maximum of 40 meters, thereafter R410 / m, Excluding VAT, extra, labor and supervision plus 20% in respect of administrative costs, consisting of labor and tool rent, but only 2½% on the cost of material.

(Special Council: 15 June 2021)

- (ii) Where a power supply to a premise with more than one consumer is provided:

AND

Where special equipment or heavier conductors than 10 mm are required or deemed necessary or where a different route, longer than that determined by the electrical Engineer, is required, full cost of such connection based on the actual cost of material, labor and supervision plus 20% administrative cost in respect of labor and tool rent, but only 2½% on the cost of materials, with a minimum payment of R24 210 per three-phase, excluding VAT and R22 310 per single phase, excluding VAT.

(Special Council: 15 June 2021)

The existing policy regarding the replacement of the same or multiphase supply remains unchanged.

(139th Amendment: June 2021)

E. (continue)

Item No

1.2.3.1 SERVICE CONNECTIONS (continue)

- (iii) That an overhead service connection tariff be accepted for the amount of R4 908.00 which excludes VAT which will only apply to a single phase overhead 10 mm connection, provided that where heavier conductors than 10 mm are required or deemed necessary, a maximum of 16 mm will be allowed at actual cost with an administrative levy of 20% and 25% levy on materials.
- (iv) That if another route is required than by the Engineer or his proxy, the full cost of such connection shall be recovered from the applicant, based on actual cost of materials, up to a maximum of 30 meters, thereafter R110.00 / m extra, excluding VAT, labor and supervision plus 20% in respect of administrative cost, consisting of labor and and tool rent, but only 2.5% on the cost of materials.
- (v) Where erfs are consolidated and subdivided or where more than one connection per erf is required, an amount of R7 790, excluding VAT will be payable per connection as a contribution to the capital fund of the electrical network, provided that where more than twelve (12) connections are required, costs will be calculated according to the attached schedule.

(Council: 15 June 2021)

1.2.3.2 SERVICES: (from 1 July 2021)

The following amounts are payable for each of the following services provided that: -

(139th Amendment: June 2021)

E. (continue)

Item No

- (i) The Engineer may at its discretion combine two or more of the following services to coincide with one visit to the consumer's premises and to recover only one money.
- (ii) If any of the services mentioned in paragraphs (a), (b), (c) or (d) below is requested between the hours of 16:15 and 07:30 and on weekends and public holidays, an amount will be charged of R243.00, EXCLUDING vat, will be payable in addition in respect of such call.
- | | | |
|--------|---|-----------|
| (a) | For start-up, transfer or temporary start-up, VAT excluded | R235.00 |
| (b) | For a special meter reading outside normal reading time, VAT excluded | R68.00 |
| (i) | For a single-phase change, excluding VAT | R385.00 |
| (ii) | For a three-phase circuit breaker change (3x80) VAT excluded | R750.00 |
| (iii) | For the test of an ordinary kilowatt hour meter excluding VAT | R462.00 |
| (c) | (iv) Prepaid meter circuit breaker change VAT excluded | R281.00 |
| (i) | For the test of a prepaid meter VAT excluded | R235.00 |
| (ii) | Linking and removing from contractor connection VAT excluded | R431.00 |
| (iii) | Temporary termination of power by consumer or contractor from VAT | R235.00 |
| (d) | (iv) Switching off temporary termination by consumer / contractor VAT | R235.00 |
| (i) | Convert from a three-phase connection to a single-phase connection with credit meter excluding VAT | R946.00 |
| (ii) | Convert from a three-phase connection to a single-phase connection with prepaid meter VAT excluded | R1 210.00 |
| (iii) | Convert from a three-phase connection to a single-phase connection with a PLC single prepayment meter excluding VAT | R2 500.00 |
| (iv) | Convert from single phase credit meter to single phase conventional prepayment meter VAT excluded | R1 100.00 |
| (v) | Convert from single phase credit meter to single-phase PLC prepaid meter (installation by Municipality) VAT excluded | R2 500.00 |
| (vi) | Convert from a three-phase credit meter to a three-phase advance payment meter excluding VAT | R2 300.00 |
| (vii) | Convert from a three-phase credit meter to a three-phase PLC prepayment meter (installation by Municipality) VAT excluded | R3 300.00 |
| (viii) | Single phase conventional prepayment meter sales price VAT out | R695.00 |
| (ix) | Single phase PLC prepayment meter sales price VAT excluded | R2 000.00 |
| (x) | Three-phase conventional prepayment meter sales price VAT out | R2 000.00 |
| (xi) | Three-phase PLC prepayment meter sales price VAT excluded | R2 900.00 |
| (xii) | Time of use meter up to 3x80 amp VAT excluded | R6 200.00 |
| (xiii) | Time of use meter 3x100 Amp and large + CTs VAT excluded | R7 250.00 |

E. (continue)

Item No

(iii) A contribution to bulk services must be paid by the developers and is calculated according to “Simplified Network Diagram” as approved by the Council on 27 June 2007, Item 8.10.

N2 Segment	R200.00 / kVA VAT excluded
N3 Segment	R450.00 / kVA, VAT excluded
N4 Segment	R660.00 / kVA. VAT excluded
N5 Segment	R320.00 / kVA. VAT excluded
N6 Segment	R1 580.00 / kVA. VAT excluded
N7 Segment	R1 490.00 / kVA VAT excluded
N8 Segment	R390.00 / KVA. VAT excluded

(Council: 15 June 2021)

(139th Amendment: June 2021)

E. (continue)

Item No

1.2.3.3 DEPOSITO: (see Delegation of Forces: Item E1.3)

The increase in the deposit is with effect from 1 July 2017 as shown below: -

Domestic consumers per amp per phase x1, VAT included	R53.00
---	--------

Trade and Industry per amp per phase x2, VAT included	R64.00
---	--------

Trade and Industrial Consumers: A bank guarantee in respect of the latter consumers can be accepted instead of a cash deposit.

Increased deposits are charged when a consumer's supply has been cut off due to no-payment and must be reconnected provided that current consumers will not be affected by this, except in the event of non-payment.

The deposit is adjusted annually by the same percentage as the increase in NERSA rates.

(Council: 15 June 2021)

(139ste Amendment: June 2021)

1.2.4 ELECTRICITY RATES: CONSUMERS OUTSIDE MUNICIPAL AREA

1.2.4.2 A deposit of R336.00, VAT included, in respect of cost estimates / quotations for the supply of electricity or any other service required by consumers within Municipal area. (From 1 July 2012)

(Council 15 June 2021)

E. (continue)

Item No

1.3 PREPAID METERS AND CREDIT METERS

1.3.1 Where positive evidence such as needle method and disconnection of a plug in a meter or the physical damage of ammeter to steal power is found: First offense.

1. The power is switched off immediately
2. A fine of R2 180 levied plus consumer loss with violation
3. Power is only switched on when full amount due to the Municipality has been paid in full.
4. Unit rate (consumer loss), VAT included R2.2441

If a person is caught for the second time for theft: -

1. The power is switched off immediately
2. A fine of R4 360.00 levied plus consumer loss with violation
3. Power is only switched on when full amount due to the Municipality has been paid in full.
4. Unit rate (consumer loss), VAT included R2.2441

(137th Amendment: May 2019)

E. (continue)

Item No

1.3 PAYMENT METERS (CONTINUE)

1.3.7 That a 10% levy be assessed for the repayment of purchasing power consumption during bridging and that it be transferred to the community in this way.

(Special Council: 21 May 2002: Item 28)

1.3.8 That where electricity supply is cut off twice in succession due to non-payment at premises, a prepaid meter is installed.

1.3.9 That a 5% surcharge is charged on after-hours power sales

(Standing Committee: Administration ea. 8 April 2003: Item 16)

(120th Amendment: May 2017)

EREKENING VAN KAPITALE NETWERK FONDS (CAPITAL NETWORK FUND)

2021 / 2022

Simplified Network diagram

(1, 88%)

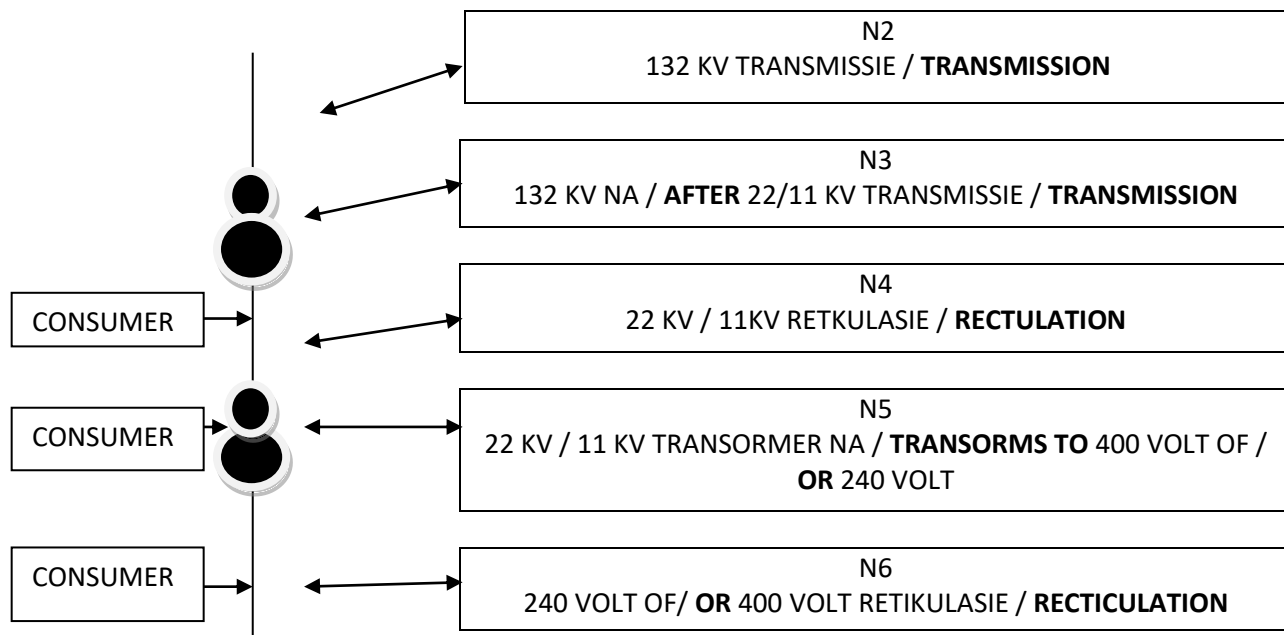

Consumer 1	=	This is a consumer with a 22 KV This is a consumer with 'n 22 KV measuring point where the transformer remains the property of the consumer.
Consumer 2	=	This is a consumer with a 240 V pf 400 V measuring point on or near the transformer.
Consumer 3	=	It is a consumer with a 240 V or 400 V measuring point, connected to a low voltage reticulation network.
Consumer 1	=	N2 + N3 + N4 R200 + R450 +R660 = R1 310.00, VAT excluded
Consumer 2	=	N2 + N3 + N4 + N5 R200 + R450 + R660 + R320 = R1 630.00, VAT excluded
Consumer 3	=	N2 + N3 + N4 + N5 + N6 R200 + R450 + R660 + R320 + R1 580 = R3 210.00, VAT excluded

F.

Item No

1. PHOTOSTATIC PRINTS

(For Deed Statements: See D.8)

Next rate for high-speed copier

R3.00 per master (official and private or public)

R3.00 per copy (official)

R3.00 per copy (private and public)

(Council: 15 June 2021)

Next rate for facsimile machine

R3.00 per page (official)

R7.00 per page (private for sending fax)

R6.00 per page (private for receiving faxes)

(Council: 15 June 2021)

Next rate for Nashua photocopier

R3.00 per copy "Toner" included (official)

R5.00 per copy (private and official)

(Council: 15 June 2021)

Next rate for Photostatic prints at Mimosa Library

R4.00 per copy A4

R5.00 Per copy A3

(Council: 15 June 2021)

F

(139th Amendment: June 2021)

G.

Item No

1. BUILDINGS

1.1 TEMPORARY STRUCTURES: (from 1 July 2021)

- 1.1.1 That, with the retention of item 4.4 (2.1.4 below) all temporary structures currently erected on private property be accepted, and that a permit be issued to each owner stating that the structures can be retained as long as it is maintained.
- 1.1.2 That all temporary structures in the auxiliary scheme area be approved and permits issued that make it clear that they can be maintained as long as they are maintained, excluding any structure other than verandas attached to a house and that such structures are erected and approved in accordance with the instructions of the City Engineer and may not be removed.
- 1.1.3 That holder of existing permits be allowed to pay arrears over a period.
- 1.1.4 That all temporary structures which serve as a storeroom, kitchen, bedroom or the loke and which are attached to a house, excluding extensions 3,5 and 14, remain conditional that they are properly maintained and there is no damage to the Council's property.
- 1.1.5 That in all the above cases where the temporary structure was legally erected, in other words, the application fees were paid, any further fees are omitted.
- 1.1.6 That the structure that is currently illegal can be legalized through the one-off payment of R94.00.
- 1.1.7 That no temporary structure, pigeon, chicken and bird cages, except on private premises, are allowed, excluding all auxiliary scheme houses purchased by means of the housing sale actions.
- 1.1.8 That any temporary structure as per definition is allowed within the auxiliary scheme housing area under the following conditions:
 - (a) Application fee of R94.00 payable
 - (b) Total maximum size of 20 square meters

(139th Amendment: June 2021)

G. (continue)

Item No

1.1.9 That temporary structures in an informal housing sector can be erected at a one – off application fee of R94.00 with a maximum size of 45 square meters.

1.1.10 Those building lines are maintained at all times as follows:

- (a) Street 2.0m
- (b) Side 1.0 m
- (c) Back 1.0 m

(Council: 15 June 2021)

1.2 MARS STORE ROOMS

(1) Store no's 1, 2 and 3 – R63.00 per month
(Including services – sanitation, water)

(2) Store no's 4 and 5 – R63.00 per month
(Including service – sanitation, water)

(3) Key deposit: R36.00

1.3 ADVERTISEMENTS

Advertising in connection with the rental or purchase of buildings
(See A 1.2)

(139th Amendment: June 2021)

G. (continue)

Item No

2.1 Fumigation of houses: (from 1 July 2021)

Fumigation of sub-economic houses: R83.00 for a maximum of two rooms: each additional room @ R41.00

Fumigation of other buildings: R94.00 per room

(Council: 15 June 2021)

2.2 Removal and destruction of rejected foodstuffs at businesses: (from 1 July 2021)

2.2.1 R239.00 plus VAT per occasion where goods are collected and destroyed by an officer.

2.2.2 R143.00 plus VAT per occasion where goods are delivered by a business for destruction by an officer

(Council June 2021)

2.3 Certificates of fitness for food premises:

The following fees for the issues of Certificates of fitness in terms of R. 918 from 30 July 1999 shall be fixed with effect from 1 August 2000:

(a) Certificates of suitability for premises where food is prepared, packaged, sold or served: R56.00

(b) Certificate of fitness for premises where food is only sold in pre-sealed containers: R29.00

(c) Certificates of suitability for premises outside the current Municipal area: existing fees plus running costs of a 1600 cc vehicle according to AA tables.

(d) Inspection for the lifting of a ban on the handling and transport of food: (Regulation 4 (6) of R.918 / 1999): actual cost

(Standing Committee: Housing.: 11 July 2000: Item 22)

(13th Amendment: May 2020)

H.

Item No

1. DETERMINATION OF RATES FOR LAND USE PLANNING APPLICATIONS IN TERMS OF THE BEAUFORT WEST MUNICIPAL LAND USE PLANNING BY-LAW, 2019

Section 15(2)(a)	Rezoning of land	R688.00
Section 15(2)(b)	Permanent departure from the development of the zoning scheme	R412.00
Section 15(2)(c)	Grant a temporary on a temporary basis for a purpose other than the permitted primary rights in terms of the zoning applicable to the property.	R412.00
Section 15(2)(d)	Subdivision of property not exempted under Section 12 including the registration of a Servitude or Lease Agreement.	R688.00 For the first 20 erf's and R138.00 for each additional erf more than 20
Section 15(2)(e)	Consolidation of property not exempted under Section 24	R688.00 For the first 20 erf's and R138.00 for each additional erf more than 20
Section 15(2)(f)	Removal, suspension or amendment of restrictive conditions in respect of a land unit	R1 034.00
Section 15(2)(g)	Permission required in terms of the zoning scheme	R276.00
Section 15(2)(h)	Amendment, deletion of imposition of conditions in respect of an existing approval	R688.00
Section 15(2)(i)	Extending the validity of an approval	R276.00
Section 15(2)(j)	Approval of an overlay zone as contemplated in the zoning scheme	R688.00
Section 15(2)(k)	Amendment or cancellation of an approved subdivision plan or any part thereof, including a general plan or diagram	R688.00 for the first 20 erf's and R138.00 for each additional erf more than 20
Section 15(2)(l)	Permission required in terms of a condition of approval	R276.00
Section 15(2)(m)	Determining a zoning	R276.00
Section 5(2)(n)	Closure of a public place or part thereof	R688.00 per erf / street or part thereof plus endorsement fees determined by Surveyor General
Section 15(2)(o)	Consent use contemplated in the zoning scheme	R688.00
Section 15(2)(p)	Social use of land	R412.00
Section 15(2)(q)	The dissolution of a homeowner's association	R688.00
Section 15(2)(r)	Correction of non-compliance with a homeowner's association's obligation with regard to the control or maintenance of services	R1 380.00
Section 15(2)(s)	Permission is required for the reconstruction of an existing building which constitutes a non-conforming use, which has been destroyed or damaged to such an extent that it is necessary to demolish a substantial part of the building.	R1 035.00

(5th Amendment 29 May 2020: Item 8.2)

H.

Item No

2. APPLICATION IN TERMS OF "LAND USE PLANNING BY-LAW OF BEAUFORT WEST MUNICIPALITY"

Section 15(2)(a)	R688.00
Section 15(2)(b)	R412.00
Section 15(2)(c)	R412.00
Section 15(2)(d)	R688.00 for the first 20 erfes and R138.00 for each additional erf more than 20
Section 15(2)(e)	R688.00 for the first 20 erfes and R138.00 for each additional erf more than 20
Section 15(2)(f)	R1 034.00
Section 15(2)(g)	R276.00
Section 15(2)(h)	R688.00
Section 15(2)(i)	R276.00
Section 15(2)(j)	R688.00
Section 15(2)(k)	R688.00 for the first 20 erfes and R138.00 for each additional erf more than 20
Section 15(2)(l)	R276.00
Section 15(2)(m)	R276.00
Section 15(2)(n)	R688.00 per erf / street or part thereof plus endorsement fees determined by the Surveyor-General
Section 15(2)(o)	R688.00
Section 15(2)(p)	R412.00
Section 15(2)(q)	R688.00
Section 15(2)(r)	R1,380.00
Section 15(2)(s)	R1 035.00

ADVERTISING COSTS

2.1	Advertisements (including the handing over of notice, registered post, data message, publication local newspaper, provincial news paper)	R2 758.00
2.2	Additional publication of notices, (e.g., field notices, public meetings, local radio station, Municipal website)	R2 758.00
2.3	Publication of decision in Provincial Gazette	R1 380.00
2.4	Integrated procedures	R688.00

(5th Amendment: 15 June 2021: Item 8.2)

I.

Item No

1. INFORMATION OF THE PUBLIC: PROVISION OF
(From 1 July 2001)

(P.K. 371/1982: 28 May 1982)

Appendix

- (a) Regarding the checking of any table of contents of an account that is not in a service registrar. R36.00
- (b) Regarding the checking of any table of contents of an account in a service register (water, sanitation, sewerage, miscellaneous debt, etc.) R36.00
- (c) For inspection in any deed, document or drawing or details in connection therewith R36.00

(Council: 15 June 2021)

- (d) (i) For the issue of a valuation certificate: - R112.00
(ii) Duplicate R56.00
- (e) (i) For the issue of a clearance certificate: - R112.00
(ii) Duplicate R56.00
- (f) With regard to tracing of information where money for such tracing is not prescribed by (a), (b) of (c) above: For each hour or part thereof with a minimum of R71.00 R75.00
- (g) Providing list of names and addresses of residents to businesses for advertising purposes R287.00

(Council: 15 June 2021)

(139th Amendment: June 2021)

K.

Item No

1. VOTER LIST

Print of voter list per ward, each

R138.00

(Council: 15 June 2021)

(139th Amendment: June 2021)

L.

Item No

1. LAND: ADVERTISEMENTS

In connection with rent or purchase of

(See Item A.2.1)

2. LOAN TABLE

(See compute: Item R.1)

3. LISENCES

(PK 483/1964; PK 1146/1974; PK 332/1978; PK 990/1971)

(108th Amendment: June 1999)

L.

Item No

3.1 DRIVERS LICENSES

- 3.1.1 That the driver's licenses test track be rented to Driving Schools after hours, provided that the Traffic Division does not use it, at R19.00 per hour.
- 3.1.2 That only light vehicles, i.e., Code 08 and fixed body Code 10 vehicles may be used by Driving Schools on the test track.
- 3.1.3 That the Business School concerned accept responsibility for any damage that may be caused during the use of the test track by such Business School.
- 3.1.4 That an amount of R332.00 be determined as a monthly rent or for a portion of a month and charged for the use of the driver's license test track by private driving schools.

3.2 DRIVERS LICENSE CARD HOLDERS

R15.00 per driver's license card holder

(Council: 15 June 2021)

3.3 HAWKERS: INFORMAL TRADE

- 1. That the current hawker area be enlarged as indicated on the plan and that the Beaufort West Business Chamber be approached for funds to develop the enlarged hawker area.
- 2. That a levy for local street vendors be set at R32.00 per month demarcated block.
- 3. That the levy for street vendors residing outside Beaufort West be set at R77.00 per day per demarcated block.
- 4. That the levies be collected as soon as the Committee on Informal Trade has submitted its recommendations on demarcated stands for hawkers.

(Council: 15 June 2021)

(139th Amendment: June 2021)

L. (continue)

Item No

4. LAND: PROPERTY TRANSACTIONS: PRINTS OF LIST OF TRANSPORT

(See D.8)

(122th Amendment: May 2005)

M.

Item No.

1. MARS ROOM STORES

(For rentals and key deposit in respect of Mars room stores see Building G.3)

2. ENGINE INPUT

(See Streets: Item S.8A)

3. MEENT

(See Town Grounds)

4. GROUNDS: UTILIZATION OF

That rents for the commonage south of the N1 and west of the Loxton Road are set at R4.00 per small stock unit.

(Special Council: 20 November 2001: Item 13: Special Resolution)

(116th Amendment December 2001)

O.

Item No

1. EXCEEDINGS

Over or on Municipal Ground: Advertising signs hanging in the air, porches etc.

Minimum fee R2.00

Pole advertisement on Municipal land R12.00
(Or part of a year)

If sign is not erected within 12 months from date of approval the fee if paid will be refunded.

2. STORAGE TANK

(See Sanitation: Item S.2)

3. SUBDIVISIONS AND REZONINGS

(See Rezoning and Subdivisions: Item H.3)

4. AUDIT COMMITTEE: (from 1 July 2021)

That the following fixed sitting allowance will be payable per meeting to the members of the Internal Audit Committee and will only be paid if a meeting does take place.

Chairperson R3000.00 per meeting
Ordinary Members R2250.00 per meeting

(Council 29 July 2019: Item 8.9)

(126th Amendment: June 2021)

P.

Item No

1. PLANS: SEWER PLANS AND OTHER PLANS

(From 1 July 2021)

Black Durester (Plastic)

841 mm roll per m R151.00
1016 mm roll per m R175.00

Paper print

841 mm roll per m R63.00
1016 mm roll per m R63.00

Ozalar & (Sephia)

841 mm roll per m R138.00
1016 mm roll per m R151.00

“Transparentized”: All sizes

R66.00

(Council: 15 June 2021)

2. POSTERS

Posting of posters, a deposit of R375.00 before the start of posting of posters, only on poles.

(139th Amendment: June 2021)

P. (cont)

Item No

3. VOëLTJIE PARK

5.1	Rent of park per day	R126.00
5.2	Rental of train Tenant is responsible for fuel as well as train driver Train driver must first be approved by Engineering Dept.	R250.00
5.3	Electricity point	R100.00
	All rates include VAT	
5.4	Key deposit	R375.00

(139th Amendment: June 2021)

P. (cont)

Item No

4. PLOTS: PRICES OF RESIDENTIAL AND INDUSTRIAL PLOTS

That erf prices in Beaufort West be determined as follows subject to the approval of the Provincial Administration (Western Cape): -

Town extension 13

Industrial area R5.60 per square meter

Town extension 4

Small subdivided R7.80 per square meter

Town extension 15

Residential plots R7.80 per square meter

Private plots South of Hooyvlakte: R7.80 per square meter

(Executive Committee: 7.8.1995)

(103th Amendment: June 1997)

S.

Item No

1. COMPUTER SERVICE

Loan table R31.00

2. SEWERAGE FEES: VAT excluded
(From 1 July 2021)

1. Every owner or occupier of premises connected to the Municipal sewerage network must pay the following fees to the Council annually:

(i) All private dwellings, economic dwellings, schools, residences, old age homes, Municipal buildings (excluding sub-economic dwellings) flats, link houses, Pathfinders, halls, churches, sports clubs and agricultural show grounds: R1 573.60 per year for each sink or urinal (measured per .6-meter lengths per site)

Private home is subject to a maximum of 2 levies unless there is also a separate apartment or link house on the property.

The Agricultural Showgrounds are only assessed for 1 sewer point.

(ii) Sub-economic housing: R434.70 per annum

(iii) Merweville: R1 327.50 per annum

(iv) Nelspoort: R666.30 per annum

(v) Businesses, offices and any other institution not specifically mentioned elsewhere: R1909.95 per annum.

(Council: 15 June 2021)

2. (i) With effect from 1 July 1984, a sanitary fee, equal to the ordinary sewerage fee, is payable by the owner of a built-up or undeveloped erf that is not connected to the Municipal sewerage network system. In the case of a build-up plot the levy is linked to the number of dwelling units on the plot.

(ii) Merweville: With effect from 1 July 2004, a sanitary fee is payable by the owner of a build-up erf that is not connected to the sewerage network, namely R192.80 per annum.

(Council: 15 June 2021)

(139th Amendment: June 2021)

S. (continue)

Item No

(iii) An undeveloped erf is classified as an erf of 200 m and larger, where the services are available, where the erf borders the street front and where there is sufficient street front to place a building.

(iv) A built-up area where the service is available and which is not connected to the sewerage network system, the levy (fee) to be linked to the number of dwelling units on the erf provided that if a building is built on two or more erf's, it will be regarded as one erf.

(Special Council: 28 May 1984: Item 5.2)

(96th Amendment: July 1995)

S. (continue)

Item No

3. SEWERAGE AND DRAINAGE
(From 1 July 1998)

4.1 SEWERAGE PLANS
(See P.3)

4.2 TEST FEES: (from 1 July 2021)

For the first and final inspection R126.00 plus R102.00 for each additional inspection.

(Council: 15 June 2021)

4.3 DEDUCTION OF STORAGE TANKS

(From 1 July 2021)

Applications for the removal of sewerage from sewerage tanks must, except where otherwise provided, be made during office hours at the office of the Local Government and fees payable in respect of such removals are as follows: -

(139th Amendment: June 2021)

S. (continue)

Item No

DEDUCTION OF STORAGE TANKS (continued)

- | | | |
|-----|---|--------------------|
| (a) | For pumping storage tanks in Industrial Area that can connect to Sewage system. | R286.00 per Load |
| (b) | For pumping of storage tanks in Industrial Area that can connect to Sewage system | R511.00 per Load |
| (c) | For pumping storage tanks on Saturdays, Sundays, Public Holidays and after office hours | R1 021.00 per Load |
| (d) | Merweville: For pumping storage tanks on Monday to Friday | R195.00 per Load |
| (e) | Merweville: For pumping storage tanks on Saturdays, Sundays, Public Holidays and after office hours | R389.00 per Load |

(Council: 15 June 2021)

4.4 MAINTAINANCE: REPAIR OF TOILETS

The following rates in respect of the placement of toilet fittings have been fixed from 1 July 2021

- | | | |
|-------|------------------------------|---------|
| (i) | Toilet pan | R956.00 |
| (ii) | Toilet sink with float valve | R389.00 |
| (iii) | Float valve | R126.00 |
| (iv) | Double folding seat | R140.00 |

VAT excluded

(Council: 15 June 2021)

4.5 EMPTY PUMP OF SEWERAGE TANKS OUTSIDE THE PROCLAIMED TOWN AREA

The tariff in respect of the emptying sewage tanks outside the proclaimed township from 1 October 1986 is adjusted as follows: -

- | | |
|-------|--|
| Truck | The rate applies per hour Plus the tariff applicable within the Township |
| Plus, | Administrative costs according to the percentage as from time to time Determined by Council. |

S. (council)

Item No

3.7 SEWERAGE: SIZE SERVICES

A contribution to major tailoring services amounting to R3 048.00 must be paid by the developers as approved by the council on 27 June 2007.

(139th Amendment: June 2021)

5. RUGBY FIELD

The rents of the rugby grounds will be charged from 1 July 2019 as follows: -

- (a) Folk festivals, cultural and Welfare organizations, churches and educational institutions where no gate or similar fees are charged- per occasion: R63.00
- (b) School's sporting events, educational institutions and tenants under 1 above where gate and similar fees are charged-per event: R188.00
- (c) Sporting events and other tenants-per event R375.00
If the land is used during the evenings after 18:00, an additional Amount of R63.00 per night will be payable in respect of lighting.
- (d) Rental of club room / rugby grounds for meetings, parties, etc., on occasion from 1 July 2021: -
 - (1) Deposit : R313.00 per event payable directly to the rugby club and refunded if no damage is done.
 - (2) Rent : R375.00 per event payable directly to rugby club

(Council: 15 June 2021)

(e) Rental of Beaufort West Sport Grounds: -

- (1) R101.00 per event in respect of training sessions
- (2) R345.00 per opportunity for hosting a match by clubs who apply for it. (In said case, it does not matter whether gate fees are charged or not).

(Council: 15 June 2021)

(f) That a prepayment meter be installed to control the floodlights on the Rustdene Sports Grounds. Special Council: 31 May 2013: item 1)

6. RUSTDENE HALL: SPEAKER DEVICE

LOUDSPEAKER – use od (excluding)

R313.00

Deposit

R313.00

(139th Amendment: June 2021)

R. (continue)

Item No

7. RUSTDENE HALL / YELLOW HALL / MERWEVILLE / KWA MANDLENKOSI : FEES: (from 1 July 2021)

	Tariff
(a) Concert (Professional Players)	R800.00
Concert (Evening)	R315.00
Concert (Day)	R70.00
(b) Public Auctions: Inside	R315.00
Public Auctions Outdoors	R70.00
(c) Presentations Workshops, Training p.h.	R70.00
(d) Church Services / Funerals: per Hour	R70.00
(e) Games nights (Church & Charity)	R170.00
Games nights (Day)	R112.00
(f) Exhibitions (Evening)	R170.00
Exhibitions (Day)	R112.00
(g) Local School Functions (Evening)	R275.00
Local School Functions (Day)	R200.00
(h) Wedding Receptions (Day)	R315.00
Wedding Receptions (Evening)	R562.00
(i) Product sales: Bazaars	R225.00
(j) Elections	R604.00
(k) Congress	R413.00
(l) Public / Political Meetings	R315.00
(m) Registered Spots and Community Organization Meetings (Day)	R70.00
Registered Sports and Community Organization Meetings (Evening)	R88.00
(n) Song Performance (Evening)	R275.00
Song Performance (Day)	R200.00
(o) Cinema screenings-Evenings (including afternoon screenings) and subject to the conditions set out in Appendix "C"	
(a) Local Schools and Churches and Charities	R170.00
(b) Other Local Institutions	R315.00
(c) Outside Persons	R652.00

(139th Amendment June 2021)

R. (continue)

Item No

(p)	Dance parties: Organized by non-Beaufort West residents	R787.00
(q)	Dance parties: Organized by people living in Beaufort West	R652.00
(r)	Dance parties: Churches, School, Charities	R413.00
(s)	Bodybuilding, Dance Exercises, Educational Purposes (Including Ballet):	
	Day	R45.00
	Evening	R51.00
(t)	Indoor Sports Exercises:	
	Day	R70.00
	Evening	R83.00
(u)	Indoor Sport Events:	
	Day	R91.00
	Evening	R131.00
(v)	Dinees :	
	Day	R226.00
	Evening	R315.00
(w)	Meals / Birthday Parties:	
	Day	R170.00
	Evening	R275.00
(x)	Banquet section additional	R91.00
(y)	S.A. Post Office Ltd: Payment of pensions (All Pay)	R329.00
(y)(1)	S.A. Post Office Ltd: Payment of pension (All Pay): Nelspoort	R329.00
(z)	Deposit: Refundable	R329.00

(Council: 15 June 2021)

- (aa) That Councilors may use halls free of charge for community meetings
- (bb) That political parties must pay for use of halls

(Standing Committee: Communities, Emergency Service, etc.: 6 June 2002: Item 2)

- (ac) That organizations that use the halls of the Council for a period of four (4) days continuously will only be assessed for three (3) days and one (1) day will be made available free of charge by the Council to the Organization.

That hall be made available to organizations in accordance with current policies and rates on Fridays, Saturdays and Sundays.

(Standing Committee: Admin ea.: June 3, 2003: Item 11)

(139th Amendment: June 2021)

Item No

R. (Continue)

THUSONG CENTRE

Conference hall: Thusong Centre	R438.00
Conference Room Plus Kitchen	R562.00
Kitchen	R151.00
Deposit: Same as Rustdene / Kwa-Mandlenkosi	R329.00

(139th Amendment: June 2021)

S.

Item No

1. SALE: RENTAL OF
(See Separate-Sale: Item 7)

Hall: Sport Centre

R375.00

(Council: 15 June 2021)

Hall: Mimosa Library
(See B.6)

- (a) That an organization uses the hall of the Council for a period of four (4) days continuously will only be assessed for three (3) days and one (1) day will be made available free of charge by the Council to the organization.
- (b) That halls be made available to organizations in accordance with current policies and rates on Fridays and Saturdays and Sundays.

(Standing Committee: Admin ea.: June 3, 2003: Item 11)

SANITARY SERVICE
(From 1 July 2021)

(1) NIGHT DIRTY REMOVAL: VAT EXCLUDED

- (b) That fees payable to the Council for the removal of night dirt from all premises are as follow:

Two removals per week: R1 631.00 per bucket per year
Three removals per week: R2 450.00 per bucket per year

The minimum removal of night dirt is twice a week

- (c) Where special or irregular removal of night dirt is undertaken from any premises, an amount of: R284.00 per bucket per removal is payable.

- (d) Merweville: Two removals per week per bucket: R1 484.00 p.y.
Merweville: After hours: R1 484.00 p.y.
Merweville: After hours R284.00
(per bucket per removal)

(Council: 15 June 2021)

(139th Amendment: June 2021)

R. (continue)

Item No

(2) A. OPERATING WASTE
(From 1 July 2021): (VAT excluded)

The fee payable by the owner or occupier to the Council for the disposal of industrial waste twice a week on days determined by the Council from time to time and placed in a container, standard refuse bin or otherwise under these regulations bound together or packed are as follows:

- (a) A minimum of R950.00 per annum for a quantity not exceeding 85 m³. This minimum is payable whether or not this service is used.
- (b) For additional quantities of industrial waste R950.00 for every 85 m³ or part thereof per year.

(Council: 15 June 2021)

(2) B. GARBAGE WASTE SITE: USED BY KAROO NATIONAL PARK

Delete

(Special Council: 11 June 2003: Item 1)

(3) HOME GARBAGE: (VAT excluded)
(From 1 July 2021)

Beaufort West

Fees payable for removal of household refuse: for a maximum of 1 removal per week R904.00 per refuse container per year with a minimum of R967.00 per year whether or not the service is used.

Merweville R852.00p.y.

Nelspoort R852.00 p.y.

(Council: 15 June 2021)

That rubbish bins be made available to H.O.P houses in Merweville for a contribution of R58.00

(139th Amendment: June 2021)

S. (continue)

Item No

- (4) A. PROPERTIES NOT YET WITHIN THE SEWER NETWORK SYSTEM
See R2.B

- (5). TEMPORARY RENTAL RENT: FEES

Movable Polythene Toilets: temporary provision and erection of: - at events etc.

(From 1 July 2021)

Rental of newly acquired polythene removable toilets

First day or part thereof	R98.00 per toilet
And for every day thereafter or part thereof	R80.00 per toilet
If toilets are delivered	R208.00 extra

(Council: 15 June 2021)

- (6). SANITRY FACILITIES ON BUILDING SITES

The tariff in respect of flush toilets for employees on building sites has been fixed at one twelfth of the sewerage fee as applicable to single dwellings per flush toilet per month with effect from 1 September 1985.

(Finance Committee: 1985.07.29: Special Resolution)

(139th Amendment: June 2021)

S. (continue)

Item No

5. CIRCUS ON TOWN LANDS

(See Item D 3.1.1 – Town lands)

6. SKUT

(See appendix attached)

7. SPORT: RUGBY Grounds

(See R.4)

SCULLETTER ANNOUNCEMENT 18 OF 1983
From 1 July 2000

ANNEX B

Basic rate of composition: 1 July 2000

Pound of animals, one or more, per occasion: R95.00

ANNEX C and D

Exceedance on built-up and unbuilt plots/erfs

Horses, cattle, ostriches and pigs per piece	R14.80
Sheep and goats per piece	R7.80

ANNEX E

Pound fees

Horses, horned cattle, pigs and ostriches per piece	R29.20
Sheep and goats per piece	R14.60

ANNEX F

Maintenance fees

Ostriches per piece per day	R14.60
Horses, horned cattle, pigs per head per day	R14.60
Sheep and goats per piece per day	R7.80

ANNEX G

Fees for animals that need to be looked after separately

For each stallion per day	R14.60
For each ostrich per day	R14.60
For each bull per day	R14.60
For each pig per day	R14.60
For each sheep ram, goat ram or other animal taken care of separately, per day	R7.80

(Spec Council: 2000.05.30: Item 4)

(111th Amendment: May 2000)

S. (continue)

Item No

(6) STREETS: TEAM OF BANNERS

(Expired: See Delegation of forces S.2.3)

8A. STREETS: ENGINE ENTRANCE: from 1 July 2008)

Actual cost
(min) 50% subsidy
(VAT included)

(Council: 27 June 2007: Item 8.10)

8B. STREETS: TARRED OF SIDE PAVEMENTS AND CAR ACCESSORIES

Works are done at real cost.

Transport and Labor:	20% Administrative Cost
Material :	2% Administrative Cost
VAT excluded	

(Special Finance Committee: 1994.03.13: Item 6: Special Resolution)

(124th Amendment: May 2007)

S. (continue)

Item No

9A. SWIMMING POOLS: TOWN, RUSTDENE, KWA-MANDLENKOSI (Youth Hub): VAT included
(from 1 July 2021)

	Children	Adults
Entrance fees:		
Swimming Tickets	R12.00	R13.00
Season tickets	R95.00	R113.00
Monthly tickets	R48.00	R59.00
Per evening (Schools etc.)		R137.00
Per morning (Schools etc.)		R125.00
Swimming exercises (Schools) – per season		R262.00
Per Swim gala		R95.00
(Council: 15 June 2021)		

Swimming pools: Town, Rustdene and Kwa-Mandlenkosi (Youth Hub)

Rental rate per season of clubs with lease agreement: -

Swimming club R1 646.00

Daily rates of clubs with lease agreement, as well as schools: -

Hourly rate R33.00
Evening rate (20:00 – 22:00) R63.00

Clubs without lease agreement, as well as public: -

Hourly rate R113.00
Evening rate (20:00 – 22:00) R262.00

(Council: 15 June 2021)

Pool rental deposit for specific occasions R376.00

(Council: 15 June 2021)

9B. SWIMMING POOL: NELSPOORT: VAT included
(From 1 July 2021)

Entrance fees:	Children	Adults
Swimming tickets	R8.00	R11.00
Season tickets	R54.00	R65.00
Monthly tickets	R30.00	R41.00

(Council: 15 June 2021)

(139th Amendment: June 2021)

S. (continue)

Item No

10. SPORT GROUNDS: RENTAL OF RUGBY FIELD AND FACILITIES

(See Rugby Field R.4)

11. BRICK MAKER: MERWEVILLE

R72.00 per 1000 brick VAT included

(Council: 15 June 2021)

(139th Amendment: June 2021)

R.

Item No

1. GARDEN REFUSE: (from 1 July 2021): VAT included

Per load from sidewalks (Beaufort West)	R273.00
--	---------

Per load from sidewalk (Merweville & Nelspoort)	R207.00
--	---------

(Council: 15 June 2021)

2. EQUIPMENT: LOAN OF CHAIRS

2.1 That where chairs, subject to their availability, are lent to private institutions and individuals, the following breakage deposit is charged: -

1 – 50 chairs	R417.00
51 – 100 chairs	R834.00
101 -150 chairs	R1 251.00

2.2 That in addition to the deposit, a rent of R8.00 per seat per event is charged.

(Council: 15 June 2021)

2.3 That a contract be drawn up between the tenant and the Council with regard to the rental of chairs and a clause be built in which states that if the tenant damages or loses chairs whose value exceeds the deposit amount, the tenant will be held liable for the outstanding amount.

(Standing Committee: Admin ea.: 15 July 2003: Item 15.3)

(139th Amendment: June 2021)

V.

Item No

1. LIVESTOCK BEADS / KRALE

Self-erected beads / kale per month

R19.00

(Executive Committee: 1998.08.24: Item 2.1.2: Special Resolution)

(139th Amendment: June 2021)

T. (continue)

Item No

2. TRAFFIC: SERVICE OF SUBSCRIPTIONS ON BEHALF OF OTHER LOCAL AUTHORITIES

The head: Traffic services, recommendation was accepted that summonses in respect of traffic offenses should henceforth be ordered by post to offenders and that if no response is received, the services of other local authorities will be use at the rates charged by the Municipal Association of Cape Town, has been proposed, viz.: -

2.1 Administration of summons: -

R39.00	for personal service
R29.00	for any other acceptable
R22.00	if no service was rendered but information was provided for re-summons
R22.00	where the summons is returned because the person could not be traced.

2.2 Administration of warrant for arrest

R85.00	for service of warrant
R34.00	if warrant returned, not served

(Council: 24 May 2005: Item 8.10.1)

3. CARRIERS

(From 1 July 2021)

That available cargo containers for the interim are rented at: - (VAT included)

3.1	6 m ³	R339.00 per month
3.2	3 m ³	R250.00 per month

(Standing Committee: Public Works, Sewerage and Engineering Service: 1998.09.16: Item 19.1)

(139th Amendment: June 2021)

W.

Item No

1A. WATER: IRRIGATION WATER: (PK 408/1980): from 1 July 2001

(e) For an erf adjoining Donkin or Birth Street in respect of certain turns of a total of eight hours per week, the sum of R193.00 per year with a reduced amount in proportion to the lengths of turns allotted for subdivisions of such erf.

(f) For an erf adjoining De Villiers, Brand, Blyth, Herman or Grimbeek Streets in respect of certain turns of a total of three hours per week, the sum of R193.00 per annum with a reduced amount in ratio to the time lengths of turns allocated for smaller erf's or subdivision of such erf.

(Special Council: 19.06.2001: Item 12.1)

1B. WATER: IRRIGATION OF GARDENS: WATER TRUCK: (from 1 July 1994)

A special service by water truck for irrigating lawns and shrubs after hours and on Saturdays at actual cost plus applicable administration rate.

(Special Finance Committee: 1994.06.13: Item 6: Special Resolution)

2. WATER: HOUSEHOLD

Availability fees

(See availability Fess Item B.5)

(115th Amendment: June 2001)

W. (continue)

Item No

3.1 WATER: TARIFF: BEAUFORT WEST

That the tariffs in respect of water supply with bill delivery from 1 July 2021 be determined as follows (**VAT Excluded**).

A minimum levy of R99.38 per month for tenants of su-economic dwellings and R172.61 per month for all other residential and industrial consumers and the following tariffs in respect of water consumption: -

(a) Credit meters

Table 1 below proves the rates for Credit meters for times of No Restrictions and also for 5 Phase of water restrictions.

Tariff	Credit Meter Tariff code	2020/21 rate	2021/22 rate
Tariff 1	A	R14.32	R15.18
Tariff 2	B	R16.44	R17.43
Tariff 3	C	R18.76	R19.89

Beaufort West Credit Meter Tariff Codes

Tariff	Consumption	No restriction <20% Water shortage	Phase 1 Restriction savings Goal 0% – 10%	Phase 2 Restriction Saving Goal 10% – 20%	Phase 3 Restriction Saving Goal 20% – 30%	Phase 4 Restriction Saving Goal 30% – 40%	Phase 5 Restriction Saving Goal 40% – 50%
		2021/22	2021/22	2021/22	2021/22	2021/22	2021/22
Tariff 1	0 - 6 kl	A	A	A	A	A	A
Tariff 2	7 - 10 kl			B	B	B	1.2B
Tariff 2	7 - 15 kl	B	B				
Tariff 3	16 - 25 kl	C	1.5B				
Tariff 3	11 - 15 kl			1.5B	2B	2B	2.5B
Tariff 4	16 - 20 kl			2B	3B	3B	3.5B
Tariff 4	26 - 35 kl	1.2B	2B				
Tariff 5	21 - 30 kl			2.85B	3.5B	3.5B	4B
Tariff 5	36 kl +++	1.5B	2.85B				
Tariff 6	31 kl +++			3.5B	4.5B	4.5B	5B
Allowance`					Consumption >15kl = 100%	Consumption >10kl = 200%	Consumption >6kl = 250%

Table 1 – Credit Meter Water Consumption Tariff Codes

Table 2 below proves the monetary value of the tariffs as laid out in Table 1. The value is rounded up to the nearest cent.

Beaufort West Credit Meter Rates

Tariff	Consumption	No Restriction	Phase 1 Restriction saving Goal 0% – 10%	Phase 2 Restriction Saving Goal 10% – 20%	Phase 3 Restriction Saving Goal 20% – 30%	Phase 4 Restriction Saving Goal 30% – 40%	Phase 5 Restriction Saving Goal 40% – 50%
		2021/22	2021/22	2021/22	2021/22	2021/22	2021/22
Basic Fees		R172.61	R172.61	R172.61	R172.61	R172.61	R172.61
Tariff 1	0 - 6 kl	R15.18	R15.18	R15.18	R15.18	R15.18	R15.18
Tariff 2	7 - 10 kl			R17.43	R17.43	R17.43	R20.92
Tariff 2	7 - 15 kl	R17.43	R17.43				
Tariff 3	16 - 25 kl	R19.89	R26.13				
Tariff 3	11 - 15 kl			R26.13	R34.84	R34.84	R43.55
Tariff 4	16 - 20 kl			R34.84	R52.27	R52.27	R60.97
Tariff 4	26 - 35 kl	R20.90	R34.84				
Tariff 5	21 - 30 kl			R49.65	R60.97	R60.97	R69.68
Tariff 5	36 kl +++	R26.13	R49.65				
Tariff 6	31 kl +++			R60.97	R78.40	R78.40	R87.11
Allowance					Consumption >15kl = 100%	Consumption >10kl = 200%	Consumption >6kl = 250%

Table 2 – Valid value of credit meter rates.

- (b) Availability fee per month: R172.60
- (c) R73.90 per month where there is not a meter on an erf, but only a standing tap for the use of more than one erf.
- (d) That in cases where there is more than one flat on a plot and the dwelling units are not all provided with a separate meter, an additional basic charge of R172.60 is charged for each dwelling unit on the premises.
- (e) Businesses

Table 3 below contains the Business Rates

Beaufort West Business Water Rates

Tariff	No Restriction <20% Water Shortage	Phase 1 Restriction Saving Goal 0% – 10%	Phase 2 Restriction Saving Goal 10% – 20%	Phase 3 Restriction Saving Goal 20% – 30%	Phase 4 Restriction Saving Goal 30% – 40%	Phase 5 Restriction Saving Goal 40% – 50%
	2021/22	2021/22	2021/22	2021/22	2021/22	2021/22
Business Code	C	C	1.5B	2B	2B	2.2B
Business Tariff	R19.89	R19.89	R26.13	R34.84	R34.84	R38.34

Table 3 – Business Water Consumption Rates

(f) Transnet According to Tariff 3: That in the case of the “Railway Barracks” as an interim measure only one basic levy of R172.60 is charged in respect of Transnet, without taxing each individual consumer with a separate basic levy.

(g) **Prepaid water meter**

Table 4 and Table 5 below prove the rates for prepaid meters for times of No Restrictions and also for 5 Phase of water restrictions.

Beaufort West Prepaid Rates Codes

Table 4 – Prepaid Meter Water Consumption Rates Codes

Beaufort West Prepaid Meter Tariff Codes

Prepaid Meters	Tariff Code	2021/22 Rate
Tariff 1	B	R15.18
Tariff 2	D	R24.03
Tariff 3	E	R26.03

Tariff	Consumption	No restrictions <20% Water Shortage	Phase 1 Restriction Saving Goal 0% – 10%	Phase 2 Restriction Saving Goal 10% – 20%	Phase 3 Restriction Saving Goal 20% – 30%	Phase 4 Restriction Saving Goal 30% – 40%	Phase 5 Restriction Saving Goal 40% – 50%
		2021/22	2021/22	2021/22	2021/22	2021/22	2021/22
Tariff 1	0 - 6 kl	D	D	D	D	D	D
Tariff 2	7 - 10 kl			E	E	E	1.2E
Tariff 2	7 - 15 kl	E	E				
Tariff 3	16 - 25 kl	E	E				
Tariff 3	11 - 15 kl			E	2B	2B	2.5B
Tariff 4	16 - 20 kl			2B	3B	3B	3.5B
Tariff 4	26 - 35 kl	E	2B				
Tariff 5	21 - 30 kl			2.85B	3.5B	3.5B	4B
Tariff 5	36 kl +++	E	2.85B				
Tariff 6	31 kl +++			3.5B	4.5B	4.5B	5B
Allowance					Consumption >15kl = 100%	Consumption >10kl = 200%	Consumption >6kl = 250%

Beaufort West Prepaid Meter rate

Tariff	Consumption	No Restriction <20% Water Shortage	Phase 1 Restriction Saving Goal 0% – 10%	Phase 2 Restriction Saving Goal 10% – 20%	Phase 3 Restriction Saving Goal 20% – 30%	Phase 4 Restriction Saving Goal 30% – 40%	Phase 5 Restriction Saving Goal 40% – 50%
		2021/22	2021/22	2021/22	2021/22	2021/22	2021/22
Tariff 1	0 - 6 kl	R24.03	R24.03	R24.03	R24.03	R24.03	R24.03
Tariff 2	7 - 10 kl			R26.03	R26.03	R26.03	R31.24
Tariff 2	7 - 15 kl	R26.03	R26.03				
Tariff 3	16 - 25 kl	R26.03	R26.03				
Tariff 3	11 - 15 kl			R26.03	R30.36	R30.36	R37.95
Tariff 4	16 - 20 kl			R30.36	R45.54	R45.54	R53.13
Tariff 4	26 - 35 kl	R26.03	R30.36				
Tariff 5	21 - 30 kl			R43.26	R53.13	R53.13	R60.72
Tariff 5	36 kl +++	R26.03	R43.26				
Tariff 6	31 kl +++			R53.13	R68.31	R68.31	R75.90
Allowance					Consumption >15kl = 100%	Consumption >10kl = 200%	Consumption >6kl = 250%

Table 5 – Prepaid Meter Water Consumption Rate

(h) Allowances during times of restrictions:

- 1) If a consumer uses more than 15kl during Phase 3 Restrictions, a surcharge of 100% will be charged on the consumption part of the account.
- 2) If a consumer uses more than 10kl during Phase 4 Restrictions, a surcharge of 200% will be charged on the consumption part of the account.
- 3) If a consumer uses more than 6kl during Phase 4 Restrictions, a surcharge of 250% will be charged on the consumption part of the account.

Restriction application Model

A new model for the application of Water Restrictions has been drawn up in accordance with the guidelines contained in the Provincial Gazette Extraordinary No. 7811 of Monday, August 21, 2017. The model determines the monthly water consumption versus water availability and makes recommendations on which Phase of Restrictions are required.

It is recommended that where consumption is less than availability, the next level of restrictions be adopted by the council within a month and where the availability of water begins to improve over a three-month period, the restriction is relaxed.

The table below proves the table contained in the Proclamation.

Column 1	Column 2	Column 3	Column 4	Column 5
LEVEL OF WATER RESTRICTIONS	TRIGGER POINT	PERCENTAGE TARGET REDUCTION IN POTABLE WATER SUPPLY AND DEMAND	TARGET CONSUMPTION OF POTABLE WATER DEMAND (EXPRESSED IN MEGALITRES PER DAY)	CALCULATED NUMBER OF REMAINING WEEKS OF BULK RAW WATER SUPPLY FOR EACH TOWN OR SETTLEMENT IN THE MUNICIPALITY (EXPRESSED AS WEEKS)
Water Conservation Measures	Permanent 100% — 81%	Baseline		
1	80% — 66%	0% — 10%		
2	65% — 51%	10% — 20%		
3	50% — 36%	20% — 30%		
4	35% — 21%	30% — 40%		
5	<20%	40% — 50%		

Table 6 – Proclamation Table

3.1 WATER : TARIFF MERWEVILLE (VAT EXCLUDED)

(a) Credit Meter

(b)

Tabel 7 en Tabel 8 below prove the rates for Credit meters for times of No Restrictions and also for 5 Phase of water restrictions.

Tariff	Credit Meter Tariff Code	2020/21 Rate	2021/22 Rate
Tariff 1	A	R7.67	R8.13
Tariff 2	B	R8.44	R8.95
Tariff 3	C	R9.21	R9.76

Merweville Credit Meter Codes

Tariff	Consumption	No Restriction <20% Water Shortage	Phase 1 Restriction	Phase 2 Restriction	Phase 3 Restriction	Phase 4 Restriction	Phase 5 Restriction
		2021/22	2021/22	2021/22	2021/22	2021/22	2021/22
Tariff 1	0 - 6 kl	A	A	A	A	A	A
Tariff 2	7 - 10 kl			B	B	B	1.2B
Tariff 2	7 - 15 kl	B	B				
Tariff 3	16 - 25 kl	1.2B	1.5B				
Tariff 3	11 - 15 kl			1.5B	2B	2B	2.5B
Tariff 4	16 - 20 kl			2B	3B	3B	3.5B
Tariff 4	26 - 35 kl	1.3B	2B				
Tariff 5	21 - 30 kl			2.85B	3.5B	3.5B	4B
Tariff 5	36 kl +++	1.4B	2.85B				
Tariff 6	31 kl +++			3.5B	4.5B	4.5B	5B
Allowance					Consumption >15kl = 100%	Consumption >10kl = 200%	Consumption >6kl = 250%

Table 7 – Credit Meter Consumption Rates Codes - Merweville

Merweville Credit Meter Rates

Tariff	Consumption	No Restriction	Phase 1 Restriction	Phase 2 Restriction	Phase 3 Restriction	Phase 4 Restriction	Phase 5 Restriction
		2021/22	2021/22	2021/22	2021/22	2021/22	2021/22
Basic Rates		R27.91	R27.91	R27.91	R27.91	R27.91	R27.91
Tariff 1	0 - 6 kl	R8.13	R8.13	R8.13	R8.13	R8.13	R8.13
Tariff 2	7 - 10 kl			R8.95	R8.95	R8.95	R10.74
Tariff 2	7 - 15 kl	R8.95	R8.95				
Tariff 3	16 - 25 kl	R10.74	R13.43				
Tariff 3	11 - 15 kl			R13.43	R17.90	R17.90	R22.38
Tariff 4	16 - 20 kl			R17.89	R26.85	R26.85	R31.32
Tariff 4	26 - 35 kl	R11.64	R17.89				
Tariff 5	21 - 30 kl			R25.50	R31.32	R31.32	R35.80
Tariff 5	36 kl +++	R12.53	R25.50				
Tariff 6	31 kl +++			R31.33	R40.28	R40.28	R44.75
Allowance					Consumption >15kl = 100%	Consumption >10kl = 200%	Consumption >6kl = 250%

Table 8 – Credit Meter Water Consumption Tariff – Merweville

(C) Business tariffs

Tariff	No Restrictions <20% Water Shortage	Phase 1 Restriction Saving Goal 0% – 10%	Phase 2 Restriction Saving Goal 10% – 20%	Phase 3 Restriction Saving Goal 20% – 30%	Phase 4 Restriction Saving Goal 30% – 40%	Phase 5 Restriction Saving Goal 40% – 50%
	2021/22	2021/22	2021/22	2021/22	2021/22	2021/22
Business Codes	C	C	1.5B	2B	2B	2.2B
Business tariff	R9.76	R9.76	R13.43	R17.89	R17.89	R19.69

(d) Prepaid Meters

Table 9 and Table 10 below prove the rates for credit meters of times of No Restrictions and also for 5 Phase of water restrictions.

Merweville Prepaid Meter Tariff Codes

Prepaid Meters	Tariff Code	2021/22 Rate
Tariff 1	A	R12.75
Tariff 2	B	R14.50

Merweville Prepaid Meters Rate Codes

Tariff	Consumption	No Restriction <20% Water Shortage	Phase 1 Restriction	Phase 2 Restriction	Phase 3 Restriction	Phase 4 Restriction	Phase 5 Restriction
		2021/22	2021/22	2021/22	2021/22	2021/22	2021/22
Tariff 1	0 - 6 kl	A	A	A	A	A	A
Tariff 2	7 - 10 kl			B	B	B	1.2B
Tariff 2	7 - 15 kl	B	B				
Tariff 3	16 - 25 kl	1.2B	1.5B				
Tariff 3	11 - 15 kl			1.5B	2B	2B	2.5B
Tariff 4	16 - 20 kl			2B	3B	3B	3.5B
Tariff 4	26 - 35 kl	1.3B	2B				
Tariff 5	21 - 30 kl			2.85B	3.5B	3.5B	4B
Tariff 5	36 kl +++	1.4B	2.85B				
Tariff 6	31 kl +++			3.5B	4.5B	4.5B	5B
Allowance					Consumption >15kl = 100%	Consumption >10kl = 200%	Consumption >6kl = 250%

Table 9 – Prepaid Meter Water Consumption Rate Codes – Merweville

Merweville Prepaid Meter Tariffs

Tariff	Consumption	No Restriction	Phase 1 Restriction	Phase 2 Restriction	Phase 3 Restriction	Phase 4 Restriction	Phase 5 Restriction
		2021/22	2021/22	2021/22	2021/22	2021/22	2021/22
Tariff 1	0 - 6 kl	R12.75	R12.75	R12.75	R12.75	R12.75	R12.75
Tariff 2	7 - 10 kl			R14.50	R14.50	R14.50	R17.40
Tariff 2	7 - 15 kl	R14.50	R14.50				
Tariff 3	16 - 25 kl	R17.40	R21.75				
Tariff 3	11 - 15 kl			R21.75	R29.00	R29.00	R36.25
Tariff 4	16 - 20 kl			R29.00	R43.50	R43.50	R50.75
Tariff 4	26 - 35 kl	R18.85	R29.00				
Tariff 5	21 - 30 kl			R41.33	R50.75	R50.75	R58.00
Tariff 5	36 kl +++	R20.30	R41.33				
Tariff 6	31 kl +++			R50.75	R65.25	R65.25	R72.50
Allowance					Consumption >15kl = 100%	Consumption >10kl = 200%	Consumption >6kl = 250%

Table 10 – Prepaid Meter Water Consumption tariffs – Merweville

WATER: TARIFF NELSPOORT (VAT EXCLUDED)

(a) Credit Meter

Tariff	Credit Meter Tariff Code	2020/21 Rate	2021/22 Rate
Tariff 1	A	R8.00	R8.48
Tariff 2	B	R9.05	R9.59
Tariff 3	C	R9.91	R10.51
Tariff 4	D	R10.83	R11.48

Nelspoort CREDIT Meter Codes

Tariff	Consumption	No Restriction <20% Water Shortage	Phase 1 Restriction Saving Goal 0% – 10%	Phase 2 Restriction Saving Goal 10% – 20%	Phase 3 Restriction Saving Goal 20% – 30%	Phase 4 Restriction Saving Goal 30% – 40%	Phase 5 Restriction saving Goal 40% – 50%
		2021/22	2021/22	2021/22	2021/22	2021/22	2021/22
Tariff 1	0 - 6 kl	A	A	A	A	A	A
Tariff 2	7 - 10 kl			B	B	B	1.2B
Tariff 2	7 - 15 kl	B	B				
Tariff 3	16 - 25 kl	C	1.5B				
Tariff 3	11 - 15 kl			1.5B	2B	2B	2.5B
Tariff 4	16 - 20 kl			2B	3B	3B	3.5B
Tariff 4	26 - 35 kl	D	2B				
Tariff 5	21 - 30 kl			2.85B	3.5B	3.5B	4B
Tariff 5	36 kl +++	1.3B	2.85B				
Tariff 6	31 kl +++			3.5B	4.5B	4.5B	5B
Allowance					Consumption >15kl = 100%	Consumption >10kl = 200%	Consumption >6kl = 250%

Nelspoort Credit Meter Tariffs

Tariff	Consumption	No Restriction	Phase 1 Restriction	Phase 2 Restriction	Phase 3 Restriction	Phase 4 Restriction	Phase 5 Restriction
		2021/22	2021/22	2021/22	2021/22	2021/22	2021/22
Basic Tariff		R95.45	R95.45	R95.45	R95.45	R95.45	R95.45
Tariff 1	0 - 6 kl	R8.48	R8.48	R8.48	R8.48	R8.48	R8.48
Tariff 2	7 - 10 kl			R9.59	R9.59	R9.59	R11.51
Tariff 2	7 - 15 kl	R9.59	R9.59				
Tariff 3	16 - 25 kl	R10.51	R14.40				
Tariff 3	11 - 15 kl			R14.40	R19.19	R19.19	R24.00
Tariff 4	16 - 20 kl			R19.19	R28.79	R28.79	R33.58
Tariff 4	26 - 35 kl	R11.48	R19.19				
Tariff 5	21 - 30 kl			R27.36	R33.58	R33.58	R38.38
Tariff 5	36 kl +++	R12.48	R27.36				
Tariff 6	31 kl +++			R33.58	R43.17	R43.17	R47.98
Allowance					Consumption >15kl = 100%	Consumption >10kl = 200%	Consumption >6kl = 250%

(b) Hospital: According to Tariff 3

R10.51

(c) Other consumers: Fixed Rate

R106.50

(d) Prepaid Meters

Nelspoort Prepaid Meter Tariff Codes

Prepaid Meters	Tariff Code	2020/21 Rate	2021/22 Rate
Tariff 1	A	R12.53	R13.28
Tariff 2	B	R14.36	R15.22
Tariff 3	C	R18.76	R19.89

Nelspoort Prepaid Meter Codes

Tariff	Consumption	No Restriction <20% Water Shortage	Phase 1 Restriction Saving Goal 0% – 10%	Phase 2 Restriction Saving Goal 10% – 20%	Phase 3 Restriction Saving Goal 20% – 30%	Phase 4 Restriction Saving Goal 30% – 40%	Phase 5 Restriction Saving Goal 40% – 50%
		2021/22	2021/22	2021/22	2021/22	2021/22	2021/22
Tariff 1	0 - 6 kl	A	A	A	A	A	A
Tariff 2	7 - 10 kl			B	B	B	1.2B
Tariff 2	7 - 15 kl	B	B				
Tariff 3	16 - 25 kl	C	C				
Tariff 3	11 - 15 kl			1.5B	2B	2B	2.5B
Tariff 4	16 - 20 kl			2B	3B	3B	3.5B
Tariff 4	26 - 35 kl	1.2B	2B				
Tariff 5	21 - 30 kl			2.85B	3.5B	3.5B	4B
Tariff 5	36 kl +++	1.5B	2.85B				
Tariff 6	31 kl +++			3.5B	4.5B	4.5B	5B
Allowance					Consumption >15kl = 100%	Consumption >10kl = 200%	Consumption >6kl = 250%

Nelspoort Prepaid Meter Tariffs

Tariff	Consumption	No Restriction <20% Water Shortage	Phase 1 Restriction on Saving Goal 0% – 10%	Phase 2 Restriction on Saving Goal 10% – 20%	Phase 3 Restriction Saving Goal 20% – 30%	Phase 4 Restriction Saving Goal 30% – 40%	Phase 5 Restricting Saving Goal 40% – 50%
		2021/22	2021/22	2021/22	2021/22	2021/22	2021/22
Tariff 1	0 - 6 kl	R13.28	R13.28	R13.28	R13.28	R13.28	R13.28
Tariff 2	7 - 10 kl			R15.22	R15.22	R15.22	R18.27
Tariff 2	7 - 15 kl	R15.22	R15.22				
Tariff 3	16 - 25 kl	R19.89	R18.89				
Tariff 3	11 - 15 kl			R22.83	R30.44	R30.44	R38.05
Tariff 4	16 - 20 kl			R30.44	R45.66	R45.66	R53.27
Tariff 5	21 - 30 kl			R43.38	R53.27	R53.27	R60.88
Tariff 5	26 - 35 kl	R18.26	R30.44				
Tariff 5	36 kl +++	R22.83	R43.38				
Tariff 6	31 kl +++			R53.27	R68.49	R68.49	R76.10
Allowance					Consumption >15kl = 100%	Consumption >10kl = 200%	Consumption >6kl = 250%

(Council: 15 June 2021)

W. (continue)

Item No

2. TOOL RENTAL

7.1 See Annexure attached
(Council: 1998.09.14: Item 7: Special Resolution)

8. WORK: PRIVATE AND DEPARTMENTAL: SERVICE FEE: 1 JULY 1994

Where a tariff has been fixed by ordinance or council decision, this tariff will also apply to interdepartmental work performed.

Where no tariff has been determined, the actual wages apply in respect of departmental works, capital works as well as private work in respect of which a head of expenditure is opened and the following wages calculated on the highest notch of the wage scale (scales) plus the leave bonus apply in respect of other private work.

(108th Amendment: June 1999)

W. (continue)

Item No

9. WORKSHOP: VEHICLE INVESTIGATION CENTRE

(From 1 July 1991)

Light testing device	R17.00 per occasion
Wheel tracking device	R8.00 per occasion
Brake test device	R8.00 per occasion
Axis mass meter	R8.00 per occasion

(Finance Committee: 1991.06.24: Item 29: Special Resolution)

(120th Amendment: June 2004)