

BEAUFORT WEST MUNICIPALITY

TARIFFS



**from
1 JULY 2024**

FEES AND RATES FOR SERVICE

A.

Item No

1.4 ABATTOIR: SEWERAGE RATES (from 1 July 2024)

An abattoir sewerage tariff in respect of private abattoirs is determined as follows to provide for the higher volume of water:

1. Grid well for catching water on slaughter floor, Beads, and water room floor
R322.47

(Special Council: 31 May 2019: Item 8.3)

2. That where detritus traps need to be repaired or replaced, an additional tariff of R2 501.60 per month will be payable in respect of abattoirs.

(Council: 26 November 2002: Item 4.26)

1.6 ABATTOIR: DISPOSAL OF ABOTTOIR WASTE

The tariff for the dumping of abattoir waste by abattoir owners in the demarcated area is determined as follows from 1 July 1993:

Actual expense – total maximum slaughter units of abattoirs using the site: fees are payable monthly.

(Finance Committee: 1993.07.26: Item 19: Special Resolution)

(142nd Amendment: June 2024)

A. (continue)

Item No

2. ADVERTISEMENTS
(See street Item S.8)

2.1 PURCHASE OR RENT OF MUNICIPAL LAND
Advertising deposit

R34.83

(Delegation of Forces L 1.1)

(Special Council: 19.6.2001: Item 12.1)

2.2 ADVERTISING COSTS: APPLICATION IN TERMS OF LAND USER ORDINANCE

(From 1 June 1994)

Together with application fees in terms of section 38 of Ordinance 15/85, an additional amount of R378.42.00 is payable, being the payment of advertising costs and advertising takes place in terms of Ordinance 15/85 after the above fees have been paid.

(Special Finance Committee: 1994.06.13: Item 6: Special Resolution)

(142nd Amendment: June 2024)

B.

Item No.

2. BANNERS: TEAM FROM STREETS

See Streets as well as Delegation of Forces S 2.3)

2. A CEMETERY: FUNERAL FEES (from 1 July 2024)

The following fees are payable to the Council in advance in respect of funerals and service rendered in the Golden Acre cemeteries under the jurisdiction of the Council in accordance with the Standard Regulations.

(a) Premises fees

(i)	Single grave	R141.57
(ii)	For one person purchased after death bought for two people after death for simultaneous funeral	R141.57
(iii)	Reserved premises	R670.79
(iv)	Grave for stillborn baby or older person under 12 years	R141.57

(b) Fees in respect of digging of grave

(From 1 July 2024)

Ordinary grave in land: -

(i)	Persons 12 years old and older (6 ft)	R1226.97
	Persons 12 years old and older (8 ft)	R1482.03

Fees in respect of excavation and burial

(ii)	Persons under the age of 12 years and still born babies	R362.92
------	---	---------

(c) Excavations and Reburial

Persons 12 years and older	R655.06
Persons under the age of 12 and still born babies	R382.02

(Council: 21 May 2024)

(142nd Amendment: June 2024)

B. (continue)

Item No.

2. ACEMETERY: FUNERAL FEES (continued)

(d)	Reopening for two burials in single grave	R147.19
(e)	Extra depth for more than one person in the same grave	R106.74
(f)	Register and Office fees	
(i)	Certified extract from register	R15.73
(ii)	Certificate of transfer	R15.73
(iii)	Checking Register	R15.84
(iv)	Exchange of premises	R15.84
(g)	Purchase of Grave site	
(i)	Excavation-Excavation of Grave	R750.56
(ii)	Premises Additional	R320.23
	In the event of a person not being able to pay the fees in respect of the digging and closing of a grave as prescribed in these regulations, he is allowed to dig and close a grave himself under the supervision of an official of the Council. However, the fees for premises as prescribed in the regulations are still payable	
(iii)	If a funeral is held on a Saturday, Sunday and Public Holiday is an additional amount of payable.	R47.19
	(P.K. 1097/1970)	
(h)	Issuance of a permit for the erection of a tombstone	R30.34
(i)	Opening of grave: Blyth Street Cemetery	
	1. The following deposit are charged in respect of burial in the cemeteries located on Blyth Street and such deposits are forfeited if graves are not made up within 12 months after funerals.	
	Graves for adults	R284.27
	Graves for children	R284.27

2. That the Cemetery on Blyth Street be extended to the east and that this section be reserved for funerals where the erection of a grave is not planned and that no deposits are charged in the relevant section.

(Special Council: 19 June 2001: Item 12.1)

3. That approval be granted that the period as permitted for the erection of graves be extended to 24 months before the deposit is forfeited.

(Council: 1999.04.26: Item 19.15)

(142nd Amendment: June 2024)

A. (continue)

Item No.

2. B CEMETERY: WALL OF MEMORIES (from 1 July 2024)

Cost per Nis (Council: 06 June 2024)	R750.56
---	---------

2. C DRY RIVER CEMETERY: FUNERAL FEES

The tariff in respect of a single grave in respect of the Dry River Cemetery was Determined as follows:

(a) For one person after death	R235.96
(b) For two persons after death for simultaneous burial	R235.96

The rest of the rates applicable to the Blyth Street Cemetery also apply to the Dry River Cemetery.

(Council: 06 June 2024)

2. D CEMETERY: TOMB PLACES: INDICATION OF: FREE GROUNDS

Designation of grave sites at Municipal freeholds	R23.60 / event
---	----------------

(Council: 06 June 2024)

2. E CEMETERY: DESIGNATION OF GRAVE: (from 1 July 2024)

A deposit of R101.00 will be charged with the allocation of a grave site and the deposit will be refundable after the grave has been dug and inspected by the City Engineer.

(Council: 21 May 2024)

2. F CEMETERY: MERWEVILLE

Kerkhof	R83.15 Single
Kerkhof	R165.17 Double

(Council: 21 May 2024)

(142nd Amendment: June 2024)

CEMETERIES

RATES From 1 July 2024

Reservations	R417.98
Permit for tombstone	R30.34
Nis: Wall of Remembrance	R752.81

TOMB PLACES

GRAVE PREMISES F/G/H/: 6 VT		GRAVE PREMISES F/G/H/: 8 VT	
Premises	R141.57	Premises	R141.57
Digging a grave	R1079.78	Digging of Grave	R1338.21
Clearance deposit	R146.07	Clearance Deposit	R146.07
Point of deposit	<u>R113.48</u>	Point of Deposit	<u>R113.48</u>
TOTAL	<u>R1,480.90</u>	TOTAL	<u>R1739.33</u>
GRAVE PREMISES A/B/C/D/J: 6 VT		GRAVE PREMISES A/B/C/D/J8 VT	
Premises	R141.57	Premises	R141.57
Digging of Grave	R1079.78	Digging of grave	R1338.21
Clearance deposit	R146.07	Clearance deposit	R146.07
Point of Deposit	<u>R113.48</u>	Point of Deposit	<u>R113.48</u>
Tombstone Deposit	<u>R284.27</u>	Tombstone deposit	<u>R284.27</u>
TOTAL	<u>R1765.17</u>	TOTAL	<u>R2023.60</u>
CHILDRE GRAVE: UNDER 9 YEARS		EXCAVATED / REBURIAL	
MATES		12 Years and older	R655.06
Premises	R141.57	Under 12 years	R382.02
Digging of grave	R222.47		
Clearance deposit	R146.07		
Point of deposit	<u>R113.48</u>		
Tombstone deposito	<u>R284.27</u>		
TOTAL	<u>R907.86</u>		

PLEASE NOTE:

Point of deposit refundable as soon as official confirms that right is buried.

Tombstone deposit refundable once tombstone has been erected within 2 years after burial.

T.

Item No.

4. TAXES

4.1a General: 1 July 2024 to 30 June 2025

Beaufort West, Merweville, Nelspoort, Murraysburg

(i)	Residential	R0.014250
(ii)	Business	R0.028500
(iii)	Industrial	R0.028500
(iv)	Public Service properties	R0.028500
(v)	PSI	R0.0
(vi)	National Monuments	R0.014250
(vii)	Agricultural	R0.001247
(viii)	Multiple use	as per allocation
(ix)	Municipal	R0.0
(x)	Nature Reserve	R0.0
(xi)	Vacant Land	R0.017100
(xii)	Mining Properties	R0.028500

(Council: 21 May 2024)

4.2A A tax rebate granted to homeowners of either single dwelling properties or who own more than one dwelling or who own a semi-detached house, provided that:

- (i) That they must occupy the property themselves
- (ii) That only a rebate is granted on one dwelling or the part the part of the link house they occupied themselves
- (iii) Be above the age of 60 years
- (iv) Not a total income derived from other sources (including a monthly income of the other half of the owner) as set out below:

R 2 205 and under	30%
R 2 206 – R 6 000	20%
R 6001 – R12 000	10%

The said discounts will only apply if the Municipal valuation of the dwelling in question is less than R 1 100 000.

The said discount is also granted to persons receiving Welfare / Disability Grants.

4.2B ALL RESIDENTIAL PROPERTIES

Additional rebate of R100 000 for all residential properties with a market value less than R190 000 reduction determined in the Rates policy

(142nd Amendment: 21 May 2024)

T. (continue)

Item No.

- 4.3 Owners of National Monuments be levied at residential tariff provided that –
- The buildings are in a satisfactory condition, and
 - The Director Engineering Services has during the second Month of each financial year submitted a report that the building is in a satisfactory condition in order that the municipality may consider whether to grant a rebate.

(Council: 21 May 2024)

- 4.4 That the following tariff be charged where an owner requests a supplementary valuation in terms of section 11 (2) (a) of the Property Valuation Ordinance, 1993.

1. Travel expenses at R2.54 per km, plus
2. Valuation fees of R2250.38

(Special Council: 28 May 2002: Item 1.2)

5. AVAILABILITY FEES
(By-Law regarding the levy of availability fees: PK 1209 of 15.12.1977)

5.1 POLICY

- 5.1.1 Accessibility fees on undeveloped ERVEN 200 m and larger are charged only where the service is available, where the erven border a street front and where there is a sufficient street front to place a building.
- 5.1.2 When the electricity or water supply to an erf is shut off for any reason and thus remains close for a continuous period of six months, availability fees are charged from the first day of the month immediately following the expiry of the six months.
- 5.1.3 In the event that the owner of an erven who pays the basic minimum fee is subsequently provided with a connection to the water or electricity supply, the availability fee ceases from the commencement of the ordinary service fee.
- 5.1.4 The City Engineer is authorized to charge availability fees in accordance with the provision of the applicable by-law and considering existing policies of the Council.

(142nd Amendment: June 2024)

T. (continue)

Item No.

- 5.1.5 The fees payable to the Council on a monthly basis by the owner of any property that is not connected to the electricity or water supply as well as the sewerage network of the Council, but which in the opinion of the Council can reasonably be connected in this way, as well as owners of prepaid meters who does not buy water is determined by the Council by Special Resolution.

(Finance Committee 2332/1.9 of 27 June 1984)

TARIFF (from 1 July 2024)

- | | | |
|-------|-------------|---------------------------------|
| (i) | Electricity | R397.99 per erven per month |
| (ii) | Water | R205.59 per month Beaufort West |
| (iii) | Water | R33.23 per month Merweville |
| (iv) | Sanitation | R156.18 per month Beaufort West |

(Council: 21 May 2024)

(142nd Amendment: June 2024)

B. (continue)

Item No.

6. LIBRARIES

A. In terms of Standard Library By-Law PK 260/1969, as amended, PK 109/1978

Duplicate tickets: (Art 296) (b))	R0.05
Discussion of library material: (Art 4)	R0.05
Preservation of library material: Art 3(5)(a))	R0.15
Information Library: Cape Town: Per call	R6.68

(Special Council: 1998.06.15: Item 2)

Rental of Library Hall

(a) Non-profit institutions and persons / institutions from outside the town's boundaries: R185.39 per event

From 1 July 2024

(b) Cultural organizations and other non-profit institutions. (Voëlklub etc.): R59.55per event

(c) Church (church purposes): R70.79 per event

(d) Creches and other school: Free

(e) Rental of kitchen: Mimosa Library

R125.84 per event from 1 July 2024

(Council: 21 May 2024)

(142nd Amendment: June 2024)

B. (continue)

Item No.

B. In terms of Standard Library By-Law: PK 640/1990: 12 October 1990

Article 3(2)(b):

A person who resides in the area of jurisdiction of the local authority for less than three months may register as a visitor if: -

(b) He/She deposits with the Librarian the deposit determined by the relevant local authority from time to time, and R36.04 per item

(Special Council: 19.6.2001: Item 12.1)

Article 7(1)(a) and 71(1)(b)

A fine for the preservation of library material after the period specified in these by-laws is charged in respect of: -

(a) Library material other than films and videos at a rate set by the local authority, but not exceeding the maximum set by the Director from time to time for a week or part of a week longer than such period, or

(b) Films and videos at a daily rate determined by the Director from time to time.

For the above: The maximum fee as determined by the Director
(Finance Committee: 1990.10.22: Item 33)

(c) Photocopy prints
R3.59 for A4 size copy; and
R4.72 for A3 size copy.

(Council: 21 May 2024)

(142nd Amendment: June 2024)

B. (continue)

Item No.

C INCREASE OF LIBRARY FINES

1. That the following library fines be levied with effect from 18 September 2000: -

Lost borrower bags: R2.36 per bag

All material (Video's included)

R1.24 per week or part thereof with a total maximum fine of R20.22.

Video's: R2.36 per day or part of a day that the item is late.

Booking of library material: maximum of R3.59 per item.

(Standing Committee: Tourism et al: 18 September 2000: Item 4)

(142nd Amendment: June 2024)

B. (continue)

Item No.

7. BUILDING PLANS

7.1 Exemption fees: (from 1 July 2024)

	Research fee	Clearance deposit
Minimum fee (any fence, pool and internal changes included)	R285.39	R423.60
0 tot 100 m ²	R21.41 / m ²	R30.34 / m ²
101 tot 200 m ²	R16.85 / m ²	R24.72 / m ²
201 tot 1 000m ²	R12.36 / m ²	R20.22 / m ²
1001 tot ∞ m ²	R2.25 / m ²	R4.49 / m ²
Maximum fee	R15519.16	R26065.27
Advertising sign	R269.66	R0.00

(Council: 21 May 2024)

7.2 Late submission of building plans: (from 1 July 2024)

If a building plan is submitted for the erection of a building after such building has already been erected or is in the process of erection, or if construction work is commenced before the plan has been approved in this regard by the local authority, a fine equal to four times the amount prescribed in respect of such plan must be paid, provided that the minimum penalty fine in respect of each building plan is R280.90 and the maximum fine of each such plan is R1375,29 in addition to the ordinary fees as in 7.1 above.

(Council: 21 May 2024)

7.3 Making available list of approved building plans: from 1 July 2024

A tariff of R104.49 has been set for making the monthly list of approved building plans available to the public.

(Council: 21 May 2024)

(142nd Amendment: June 2024)

D.

Item No

1. ANIMALS

1.1 Continuation on Village Land

See withdrawal Item 5

1.2 Removal of dead animals: (from 1 July 2024)

Cattle, horse, donkey, mule, pig / opportunity
Sheep, goat / opportunity

R297.75

R149.44

(Council: 21 May 2024)

(142nd Amendment: June 2024)

D.

Item No

2. VILLAGE LAND

2.1 Circus per day R595.51
(On site as determined by Council) Service included

Inspection fee in respect of the above R106.74

On site in private R106.74

(Council: 21 May 2024)

2.2 Site for accommodation of temporary work teams of Contractor on site as determined by Council

2.3 The site at the soccer field in Newtown is made available for a circus (See 3.1)

2.4 The contractors must install a wire mesh fence at least 1.5 m high around the site they are renting.

2.5 Contractors must arrange with the Head: Health Service and Cleaning regarding the installation of bucket facilities at their own expense and accept responsibility for the cost of removal.

2.6 Domestic water connections are provided at the rate laid down and water consumption is paid at the existing rate.

3. TOWN LAND: REMOVAL OF:

(From 1 July 2024): VAT included

Sand per m ³	With a minimum	R77.53	R77.53
Soil per m ³	With a minimum	R77.53	R77.53
Gravel per m ³	With a minimum	R119.10	R125.84
Flat stone per m ³	With a minimum	R73.03	R77.53

(Council: 21 May 2024)

(142nd Amendment: June 2024)

D.

Item No

4. DRAINING AND SEWERAGE

(See Sewerage: Item R2)

5. MISCELLANEOUS: LAND AND GROUND: PROPERTY TRANSACTIONS: PRINTS OF LIST OF TRANSPORTERS

A4 sheet of return with transfers of real property located in Beaufort West Municipal area and registered in the Deeds Office in Cape Town including all financial institutions and building societies available on request: -

R39.33 per sheet

(Council: 21 May 2024)

(142nd Amendment: June 2024)

Electricity Tariffs will be published separately

E (continue)

Item No

1.2.3.1 SERVICE CONNECTIONS

The following fees are payable to the Council with effect from 1 July 2024 in respect of three-phases or single-phase underground service connections.

- (i) Where the power supply to a premise is provided with only one consumer, R30 193.91 for a three-phase connection and R27 824.24 for a single-phase connection excluding VAT, provided that where special equipment or heavier conductors require or require 10mm is deemed. Or where another route is required longer than determined by the Electrotechnical Engineer, the full cost such connection is recovered from the applicant based on actual cost of materials, up to a maximum of 40 meters, thereafter R511.82 / m, Excluding VAT, extra, labor and supervision plus 20% in respect of administrative costs, consisting of labor and tool rent, but only 2½% on the cost of material.

(Council: 21 May 2024)

- (ii) Where a power supply to a premise with more than one consumer is provided:

AND

Where special equipment or heavier conductors than 10 mm are required or deemed necessary or where a different route, longer than that determined by the electrical Engineer, is required, full cost of such connection based on the actual cost of material, labor, and supervision plus 20% administrative cost in respect of labor and tool rent, but only 2½% on the cost of materials, with a minimum payment of R30 193.91 per three-phase, excluding VAT and R27 824.24 per single phase, excluding VAT.

(Special Council: 21 May 2024)

The existing policy regarding the replacement of the same or multiphase supply remains unchanged.

Reconnection of Electricity Meters: R 322. 24 (Credit Control)

(142nd Amendment: June 2024)

E. (continue)

Item No

1.2.3.1 SERVICE CONNECTIONS (continue)

- (iii) That an overhead service connection tariff be accepted for R6120.67 which excludes VAT which will only apply to a single phase overhead 10 mm connection, provided that where heavier conductors than 10 mm are required or deemed necessary, a maximum of 16 mm will be allowed at actual cost with an administrative levy of 20% and 25% levy on materials.
- (iv) That if another route is required than by the Engineer or his proxy, the full cost of such connection shall be recovered from the applicant, based on actual cost of materials, up to a maximum of 30 meters, thereafter R136.49 / m extra, excluding VAT, labor, and supervision plus 20% in respect of administrative cost, consisting of labor and tool rent, but only 2.5% on the cost of materials.
- (v) Where ervens are consolidated and subdivided or where more than one connection per erven is required, an amount of R9 850.50, excluding VAT will be payable per connection as a contribution to the capital fund of the electrical network, provided that where more than twelve (12) connections are required, costs will be calculated according to the attached schedule.

(Council: 21 May 2024)

(142nd Amendment: June 2024)

E. (continue)

1.2.3.1 SERVICES: (from 1 July 2024)

The following amounts are payable for each of the following services provided that: -

- (i) The Engineer may at its discretion combine two or more of the following services to coincide with one visit to the consumer's premises and to recover only one money.
- (ii) If any of the services mentioned in paragraphs (a), (b), (c) or (d) below is requested between the hours of 16:15 and 07:30 and on weekends and public holidays, an amount will be charged of R303.56, EXCLUDING vat, will be payable in addition in respect of such call.

(a)	For start-up, transfer or temporary start-up, VAT excluded	R292.97
(b)	For a special meter reading outside normal reading time, VAT excluded	R84.72
	(i) For a single-phase change, excluding VAT	R480.05
	(ii) For a three-phase circuit breaker change (3x80) VAT excluded	R935.40
	(iii) For the test of an ordinary kilowatt hour meter excluding VAT	R576.53
(c)	(iv) Prepaid meter circuit breaker change VAT excluded	R350.63
	(i) For the test of a prepaid meter VAT excluded	R292.97
	(ii) Linking and removing from contractor connection VAT excluded	R537.71
	(iii) Temporary termination of power by consumer or contractor from VAT	R292.97
(d)	(iv) Switching off temporary termination by consumer / contractor VAT	R292.97
	(i) Convert from a three-phase connection to a single-phase connection with credit meter excluding VAT	R1180.13
	(ii) Convert from a three-phase connection to a single-phase connection with prepaid meter VAT excluded	R1509.58
	(iii) Convert from a three-phase connection to a single-phase connection with a PLC single prepayment meter excluding VAT	R3117.99
	(iv) Convert from single phase credit meter to single phase conventional prepayment meter VAT excluded	R1371.92
	(v) Convert from single phase credit meter to single-phase PLC prepaid meter (installation by Municipality) VAT excluded	R3117.99
	(vi) Convert from a three-phase credit meter to a three-phase advance payment meter excluding VAT	R2868.55
	(vii) Convert from a three-phase credit meter to a three-phase PLC prepayment meter (installation by Municipality) VAT excluded	R4115.75
	(viii) Single phase conventional prepayment meter sales price VAT out	R868.33
	(ix) Single phase PLC prepayment meter sales price VAT excluded	R2494.39
	(x) Three-phase conventional prepayment meter sales price VAT out	R2494.39
	(xi) Three-phase PLC prepayment meter sales price VAT excluded	R3616.87
	(xii) Time of use meter upto 3x80amp VAT excluded	R7732.62
	(xiii) Time of use meter 3x100 Amp and large + CTs VAT excluded	R9042.17

E. (continue)

Item No

(iii) A contribution to bulk services must be paid by the developers and is calculated according to "Simplified Network Diagram" as approved by the Council on 27 June 2007, Item 8.10.

N2 Segment	R274.47	/ kVA	VAT excluded
N3 Segment	R618.36	/ kVA	VAT excluded
N4 Segment	R905.83	/ kVA.	VAT excluded
N5 Segment	R439.49	/ kVA.	VAT excluded
N6 Segment	R2169.38	/ kVA.	VAT excluded
N7 Segment	R2045.45	/ kVA	VAT excluded
N8 Segment	R535.32	/ KVA.	VAT excluded

(Council: 21 May 2024)

(142nd Amendment: June 2024)

E. (continue)

Item No

1.2.3.2 DEPOSITO: (see Delegation of Forces: Item E1.3)

The increase in the deposit is with effect from 1 July 2024 as shown below: -

Domestic consumers per amp per phase x1, VAT included R72.83

Trade and Industry per amp per phase x2, VAT included R88.16

Trade and Industrial Consumers: A bank guarantee in respect of the latter consumers can be accepted instead of a cash deposit.

Increased deposits are charged when a consumer's supply has been cut off due to no-payment and must be reconnected provided that current consumers will not be affected by this, except in the event of non-payment.

The deposit is adjusted annually by the same percentage as the increase in NERSA rates.

(Council: 21 May 2024)

(142nd Amendment: June 2024)

1.2.4 ELECTRICITY RATES: CONSUMERS OUTSIDE MUNICIPAL AREA

1.2.4.2 A deposit of R418.89 VAT included, in respect of cost estimates / quotations for the supply of electricity or any other service required by consumers within Municipal area.
(From 1 July 2024)

(Council 21 May 2024)

(142nd Amendment: June 2024)

1.3 PREPAID METERS AND CREDIT METERS

1.3.1 Where positive evidence such as needle method and disconnection of a plug in a meter or the physical damage of ammeter to steal power is found: First offense.

1. The power is switched off immediately
2. A fine of R2 632.59 levied plus consumer loss with violation
3. Power is only switched on when full amount due to the Municipality has been paid in full.
4. Unit rate (consumer loss), VAT included R3.427

If a person is caught for the second time for theft: -

1. The power is switched off immediately
2. A fine of R5 265.19 levied plus consumer loss with violation
3. Power is only switched on when full amount due to the Municipality has been paid in full.
4. Unit rate (consumer loss), VAT included R3.427

Item No

1.3 PAYMENT METERS (CONTINUE)

1.3.7 That a 10% levy be assessed for the repayment of purchasing power consumption during bridging and that it be transferred to the community in this way.

(Special Council: 21 May 2002: Item 28)

1.3.8 That where electricity supply is cut off twice in succession due to non-payment at premises, a prepaid meter is installed.

1.3.9 That a 5% surcharge is charged on after-hours power sales
(Standing Committee: Administration ea. 8 April 2003: Item 16)

(142nd Amendment: June 2024)

EREKENING VAN KAPITALE NETWERK FONDS (CAPITAL NETWORK FUND)

2023 / 2024

Simplified Network diagram

(1, 88%)

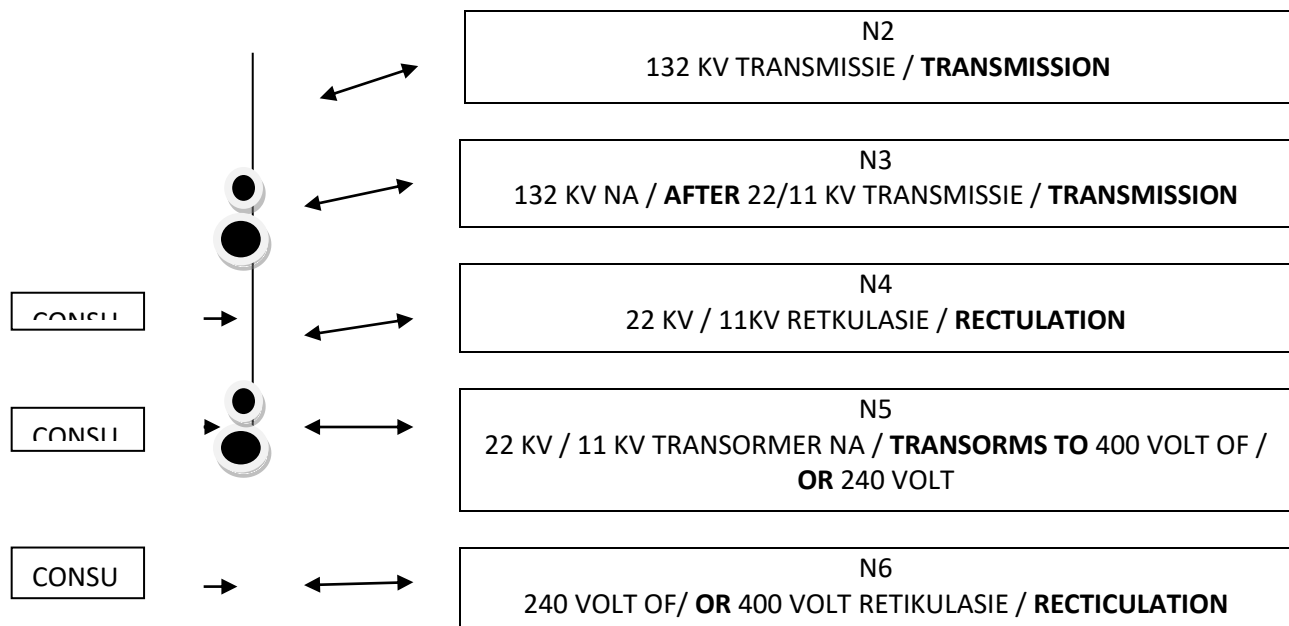

Consumer 1	=	This is a consumer with a 22 KV This is a consumer with 'n 22 kV measuring point where the transformer remains the property of the consumer.
Consumer 2	=	This is a consumer with a 240 V pf 400 V measuring point on or near the transformer.
Consumer 3	=	It is a consumer with a 240 V or 400 V measuring point, connected to a low voltage reticulation network.
Consumer 1	=	N2 + N3 + N4 R274.69 + R618.36 + R905.83 = R1 798.88, VAT excluded

Consumer 2	=	N2 + N3 + N4 + N5 R274.69 + R618.36 + R905.83 + R439.49 = R2 238.37, VAT excluded
Consumer 3	=	N2 + N3 + N4 + N5 + N6 R274.69 + R618.36 + R905.83 + R439.49 + R2169.38 = R4 407.75, VAT excluded

F.

Item No

1. PHOTOSTATIC PRINTS

(For Deed Statements: See D.8)

Next rate for high-speed copier

R3.59 per master (official and private or public)

R3.59 per copy (official)

R3.59 per copy (private and public)

(Council: 21 May 2024)

Next rate for facsimile machine

R3.59 per page (official)

R8.31 per page (private for sending fax)

R7.19 per page (private for receiving faxes)

(Council: 21 May 2024)

Next rate for Nashua photocopier

R3.59 per copy "Toner" included (official)

R5.96 per copy (private and official)

(Council: 21 May 2024)

Next rate for Photostatic prints at Mimosa Library

R4.72 per copy A4

R5.96 Per copy A3

(Council: 21 May 2024)

(142nd Amendment: June 2024)

G.

Item No

1. BUILDINGS

1.1 TEMPORARY STRUCTURES: (from 1 July 2024)

- 1.1.1 That, with the retention of item 4.4 (2.1.4 below) all temporary structures currently erected on private property be accepted, and that a permit be issued to each owner stating that the structures can be retained as long as it is maintained.
- 1.1.2 That all temporary structures in the auxiliary scheme area be approved and permits issued that make it clear that they can be maintained if they are maintained, excluding any structure other than verandas attached to a house and that such structures are erected and approved in accordance with the instructions of the City Engineer and may not be removed.
- 1.1.3 That holder of existing permits be allowed to pay arrears over a period.
- 1.1.4 That all temporary structures which serve as a storeroom, kitchen, bedroom or the like and which are attached to a house, excluding extensions 3,5 and 14, remain conditional that they are properly maintained and there is no damage to the Council's property.
- 1.1.5 That in all the above cases where the temporary structure was legally erected, in other words, the application fees were paid, any further fees are omitted.
- 1.1.6 That the structure that is currently illegal can be legalized through the one-off payment of R112.36.
- 1.1.7 That no temporary structure, pigeon, chicken, and bird cages, except on private premises, are allowed, excluding all auxiliary scheme houses purchased by means of the housing sale actions.
- 1.1.8 That any temporary structure as per definition is allowed within the auxiliary scheme housing area under the following conditions:
 - (a) Application fee of R112.36 payable
 - (b) Total maximum size of 20 square meters

(142nd Amendment: June 2024)

G. (continue)

Item No

1.1.9 That temporary structures in an informal housing sector can be erected at a one – off application fee of R112.36 with a maximum size of 45 square meters.

1.1.10 Those building lines are always maintained as follows:

- (a) Street 2.0m
- (b) Side 1.0 m
- (c) Back 1.0 m

(Council: 21 May 2024)

1.2 MARS STORE ROOMS

(1) Store no's 1, 2 and 3 – R75.28 per month
(Including services – sanitation, water)

(2) Store no's 4 and 5 – 75.28 per month
(Including service – sanitation, water)

(3) Key deposit: R42.70

1.3 ADVERTISEMENTS

Advertising in connection with the rental or purchase of buildings
(See A 1.2)

(142nd Amendment: June 2024)

G. (continue)

Item No

2.1 Fumigation of houses: (from 1 July 2024)

Fumigation of sub-economic houses: R93.28 for a maximum of two rooms: each additional room @ R46.64

Fumigation of other buildings: R112.36 per room

(Council: 21 May 2024)

2.2 Removal and destruction of rejected foodstuffs at businesses: (from 1 July 2024)

2.2.1 R268.18 plus VAT per occasion where goods are collected and destroyed by an officer.

2.2.2 R161.12 plus VAT per occasion where goods are delivered by a business for destruction by an officer

(Council: 21 May 2024)

2.3 Certificates of fitness for food premises:

The following fees for the issues of Certificates of fitness in terms of R. 918 from 30 July 1999 shall be fixed with effect from 1 August 2000:

(a) Certificates of suitability for premises where food is prepared, packaged, sold, or served: R66.29

(b) Certificate of fitness for premises where food is only sold in pre-sealed containers: R34.83

(c) Certificates of suitability for premises outside the current Municipal area: existing fees plus running costs of a 1600 cc vehicle according to AA tables.

(d) Inspection for the lifting of a ban on the handling and transport of food: (Regulation 4 (6) of R.918 / 1999): actual cost

(Standing Committee: Housing: 11 July 2000: Item 22)

(142nd Amendment: June 2024)

H.

Item No

1. DETERMINATION OF RATES FOR LAND USE PLANNING APPLICATIONS IN TERMS OF THE BEAUFORT WEST MUNICIPAL LAND USE PLANNING BY-LAW, 2019

Section 15(2)(a)	Rezoning of land	R819.10
Section 15(2)(b)	Permanent departure from the development of the zoning scheme	R491.01
Section 15(2)(c)	Grant a temporary on a temporary basis for a purpose other than the permitted primary rights in terms of the zoning applicable to the property.	R491.01
Section 15(2)(d)	Subdivision of property not exempted under Section 12 including the registration of a Servitude or Lease Agreement.	R819.10 For the first 20 erven and R164.76 for each additional erven more than 20
Section 15(2)(e)	Consolidation of property not exempted under Section 24	R819.10 For the first 20 erven and R164.76 for each additional erven more than 20
Section 15(2)(f)	Removal, suspension or amendment of restrictive conditions in respect of a land unit	R1231.47
Section 15(2)(g)	Permission required in terms of the zoning scheme	R329.21
Section 15(2)(h)	Amendment, deletion of imposition of conditions in respect of an existing approval	R819.10
Section 15(2)(i)	Extending the validity of an approval	R329.21
Section 15(2)(j)	Approval of an overlay zone as contemplated in the zoning scheme	R819.10
Section 15(2)(k)	Amendment or cancellation of an approved subdivision plan or any part thereof, including a general plan or diagram	R819.10 for the first 20 erven and R164.76 for each additional erven more than 20
Section 15(2)(l)	Permission required in terms of a condition of approval	R329.21
Section 15(2)(m)	Determining a zoning	R329.21
Section 5(2)(n)	Closure of a public place or part thereof	R819.10 per erven / street or part thereof plus endorsement fees determined by Surveyor General
Section 15(2)(o)	Consent use contemplated in the zoning scheme	R819.10
Section 15(2)(p)	Social use of land	R491.01
Section 15(2)(q)	The dissolution of a homeowner's association	R819.10
Section 15(2)(r)	Correction of non-compliance with a homeowner's association's obligation with regard to the control or maintenance of services	R1643.83
Section 15(2)(s)	Permission is required for the reconstruction of an existing building which constitutes a non-conforming use, which has been destroyed or damaged to such an extent that it is necessary to demolish a substantial part of the building.	R1232.59

H.

Item No

2. ADVERTISING COST FOR LAND USE PLANNING APPLICTAIONS

2.1	Advertisements (including the handing over of notice, registered post, data message, publication local newspaper, provincial news paper	R3285.41
2.2	Additional publication of notices, (e.g., field notices, public meetings, local radio station, Municipal website)	R3285.41
2.3	Publication of decision in Provincial Gazette	R1643.83
2.4	Integrated procedures	R819.10

3. APPEAL FEES FOR LAND USE APPLICATIONS

Land Use Appeal Fee

R10100.04

(Council, 29 May 2020, item 8.2.5)

I.

Item No

**1. INFORMATION OF THE PUBLIC: PROVISION OF
(From 1 July 2024)**

(P.K. 371/1982: 28 May 1982)

Appendix

- (a) Regarding the checking of any table of contents of an account that is not in a service registrar. R40.28
- (b) Regarding the checking of any table of contents of an account in a service register (water, sanitation, sewerage, miscellaneous debt, etc.) R40.28
- (c) For inspection in any deed, document or drawing or details in connection therewith R40.28
- (d) (i) For the issue of a valuation certificate: - R133.71
(ii) Duplicate R66.29
- (e) (i) For the issue of a clearance certificate: - R133.71
(ii) Duplicate R66.29
- (f) With regards to tracing of information where money for such tracing is not

prescribed by (a), (b) of (c) above: For each hour or part thereof with a minimum of R79.50 R89.89

(g) Providing list of names and addresses of residents to businesses for advertising purposes R341.57

(Council: 21 May 2024)

K.

Item No

1. VOTER LIST

Print of voter list per ward, each R164.05

(Council: 21 May 2024)

(142nd Amendment: June 2024)

L.

Item No

1. LAND: ADVERTISEMENTS

In connection with rent or purchase of

(See Item A.2.1)

2. LOAN TABLE

(See compute: Item R.1)

3. LISENCES

(PK 483/1964; PK 1146/1974; PK 332/1978; PK 990/1971)

(142nd Amendment: June 2024)

L.

Item No

3.1 DRIVERS LICENSES

- 3.1.1 That the driver's licenses test track be rented to Driving Schools after hours, provided that the Traffic Division does not use it, at R22.47 per hour.
- 3.1.2 That only light vehicles, i.e., Code 08 and fixed body Code 10 vehicles may be used by Driving Schools on the test track.
- 3.1.3 That the Business School concerned accept responsibility for any damage that may be caused during the use of the test track by such Business School.
- 3.1.4 That an amount of R35.11 be determined as a monthly rent or for a portion of a month and charged for the use of the driver's license test track by private driving schools.

3.2 DRIVERS LICENSE CARD HOLDERS

R17.98 per driver's license card holder

(Council: 21 May 2024)

3.3 HAWKERS: INFORMAL TRADE

- 1. That the current hawker area be enlarged as indicated on the plan and that the Beaufort West Business Chamber be approached for funds to develop the enlarged hawker area.
- 2. That a levy for local street vendors be set at R38.20 per month demarcated block.
- 3. That the levy for street vendors residing outside Beaufort West be set at R92.14 per day per demarcated block.
- 4. That the levies be collected as soon as the Committee on Informal Trade has submitted its recommendations on demarcated stands for hawkers.

(Council: 21 May 2024)

(142nd Amendment: June 2024)

L. (continue)

Item No

4. LAND: PROPERTY TRANSACTIONS: PRINTS OF LIST OF TRANSPORT

(See D.8)

(142nd Amendment: June 2024)

M.

Item No.

1. MARS ROOM STORES

(For rentals and key deposit in respect of Mars room stores see Building G.3)

2. ENGINE INPUT

(See Streets: Item S.8A)

3. MEENT

(See Town Grounds)

4. GROUNDS: UTILIZATION OF

That rents for the commonage south of the N1 and west of the Loxton Road are set at R4.72 per small stock unit.

(Special Council: 20 November 2001: Item 13: Special Resolution)

(142nd Amendment June 2024)

O.

Item No

1. EXCEEDINGS

Over or on Municipal Ground: Advertising signs hanging in the air, porches etc.

Minimum fee R2.36

Pole advertisement on Municipal land R14.61
(Or part of a year)

If sign is not erected within 12 months from date of approval the fee if paid will be refunded.

2. STORAGE TANK

(See Sanitation: Item S.2)

3. SUBDIVISIONS AND REZONINGS

(See Rezoning and Subdivisions: Item H.3)

4. AUDIT COMMITTEE: (from 1 July2024)

That the following fixed sitting allowance will be payable per meeting to the members of the Internal Audit Committee and will only be paid if a meeting does take place.

Chairperson R3 578.05 per meeting

Ordinary Members R2 679.79 per meeting

(Council 29 July 2019: Item 8.9)

(142nd Amendment: June 2024)

P.

Item No

1. PLANS: SEWER PLANS AND OTHER PLANS

(From 1 July 2024)

Black Durester (Plastic)

841 mm roll per m R179.78
1016 mm roll per m R208.99

Paper print

841 mm roll per m R75.28
1016 mm roll per m R75.28

Ozalar & (Sephia)

841 mm roll per m R164.05
1016 mm roll per m R179.78

“Transparentized”: All sizes

R78.65

(Council: 21 May 2024)

2. POSTERS

Posting of posters, a deposit of R447.19 before the start of posting of posters, only on poles.

(142nd Amendment: June 2024)

P. (cont)

Item No

3. VOËLTJIE PARK

5.1	Rent of park per day	R150.56
5.2	Rental of train Tenant is responsible for fuel as well as train driver Train driver must first be approved by Engineering Dept.	R297.75
5.3	Electricity point All rates include VAT	R119.10
5.4	Key deposit	R447.19

(142nd Amendment: June 2024)

P. (cont)

Item No

4. PLOTS: PRICES OF RESIDENTIAL AND INDUSTRIAL PLOTS

That erven prices in Beaufort West be determined as follows subject to the approval of the Provincial Administration (Western Cape): -

Town extension 13

Industrial area R6.63 per square meter

Town extension 4

Small subdivided R9.33 per square meter

Town extension 15

Residential plots R9.33 per square meter

Private plots South of Hooyvlakte: R9.33 per square meter

(Executive Committee: 7.8.1995)

(142nd Amendment: June 2024)

S.

Item No

1. COMPUTER SERVICE

Loan table

R37.08

2. SEWERAGE FEES: VAT excluded
(From 1 July 2024)

1. Every owner or occupier of premises connected to the Municipal sewerage network must pay the following fees to the Council annually:

(i) All private dwellings, economic dwellings, schools, residences, old age homes, Municipal buildings (excluding sub-economic dwellings) flats, link houses, Pathfinders, halls, churches, sports clubs, and agricultural show grounds: R1874.16 per year for each sink or urinal (measured per .6-meter lengths per site)

Private home is subject to a maximum of 2 levies unless there is also a separate apartment or link house on the property.

The Agricultural Showgrounds are only assessed for 1 sewer point.

(ii) Sub-economic housing: R549.06 per annum

(iii) Merweville: R1675.76 per annum

(iv) Nelspoort: R840.09 per annum

(v) Businesses, offices, and any other institution not specifically mentioned elsewhere: R2 555.93 per annum.

(Council: 21 May 2024)

2. (i) With effect from 1 July 1984, a sanitary fee, equal to the ordinary sewerage fee, is payable by the owner of a built-up or undeveloped erven that is not connected to the Municipal sewerage network system. In the case of a build-up plot the levy is linked to the number of dwelling units on the plot.

(ii) Merweville: With effect from 1 July 2004, a sanitary fee is payable by the owner of a build-up erven that is not connected to the sewerage network, namely R229.66 per annum.

(Council: 21 May 2024)

(142nd Amendment: June 2024)

S. (continue)

Item No

(iii) An undeveloped erf is classified as an erf of 200 m and larger, where the services are available, where the erven border the street front and where there is sufficient street front to place a building.

(iv) A built-up area where the service is available and which is not connected to the sewerage network system, the levy (fee) to be linked to the number of dwelling units on the erven provided that if a building is built on two or more erven, it will be regarded as one erf.

(Special Council: 28 May 1984: Item 5.2)

(142nd Amendment: June 2024)

S. (continue)

Item No

3. SEWERAGE AND DRAINAGE
(From 1 July 2024)

4.1 SEWERAGE PLANS
(See P.3)

4.2 TEST FEES: (from 1 July 2024)

For the first and final inspection R150.56 plus R121.35 for each additional inspection.

(Council: 21 May 2024)

4.3 DEDUCTION OF STORAGE TANKS

(From 1 July 2024)

Applications for the removal of sewerage from sewerage tanks must, except where otherwise provided, be made during office hours at the office of the Local Government and fees payable in respect of such removals are as follows: -

(142nd Amendment: June 2024)

S. (continue)

Item No

DEDUCTION OF STORAGE TANKS (continued)

(a)	For pumping storage tanks in Industrial Area that can connect to Sewage system.	R340.45 per Load
(b)	For pumping of storage tanks in Industrial Area that can connect to Sewage system	R608.99 per Load
(c)	For pumping storage tanks on Saturdays, Sundays, Public Holidays and after office hours	R1215.74 per Load
(d)	Merweville: For pumping storage tanks on Monday to Friday	R232.59 per Load
(e)	Merweville: For pumping storage tanks on Saturdays, Sundays, Public Holidays and after office hours	R462.92 per Load

(Council: 21 May 2024)

4.4 MAINTAINANCE: REPAIR OF TOILETS

The following rates in respect of the placement of toilet fittings have been fixed from 1 July 2024

(i)	Toilet pan	R1138.21
(ii)	Toilet sink with float valve	R462.92
(iii)	Float valve	R150.56
(iv)	Double folding seat	R166.29

VAT excluded

(Council: 21 May 2024)

4.5 EMPTY PUMP OF SEWERAGE TANKS OUTSIDE THE PROCLAIMED TOWN AREA

The tariff in respect of the emptying sewage tanks outside the proclaimed township from 1 October 1986 is adjusted as follows: -

Truck	The rate applies per hour Plus the tariff applicable within the Township
Plus,	Administrative costs according to the percentage as from time to time Determined by Council.

S. (council)

Item No

3.7 SEWERAGE: SIZE SERVICES

A contribution to major tailoring services amounting to R3630.35 must be paid by the developers as approved by the council on 27 June 2007.

(142nd Amendment: June 2024)

5. RUGBY FIELD

The rents of the rugby grounds will be charged from 1 July 2019 as follows: -

(a) Folk festivals, cultural and Welfare organizations, churches, and educational institutions where no gate or similar fees are charged- per occasion: R75.28

(b) School's sporting events, educational institutions, and tenants under 1 above where gate and similar fees are charged-per event: R223.60

(c) Sporting events and other tenants-per event R447.19
If the land is used during the evenings after 18:00, an additional Amount of R75.28 per night will be payable in respect of lighting.

(d) Rental of club room / rugby grounds for meetings, parties, etc., on occasion from 1 July 2024: -

(1) Deposit : R361.80 per event payable directly to the rugby club and refunded if no damage is done.

(2) Rent : R447.11 per event payable directly to rugby club

(Council: 21 May 2024)

(e) Rental of Beaufort West Sport Grounds: -

(1) R120.23 per event in respect of training sessions

(2) R411.24 per opportunity for hosting a match by clubs who apply for it. (In said case, it does not matter whether gate fees are charged or not).

(Council: 21 May 2024)

(f) That a prepayment meter be installed to control the floodlights on the Rustdene Sports Grounds. Special Council: 31 May 2013: item 1)

6. RUSTDENE HALL: SPEAKER DEVICE

LOUDSPEAKER – use of (excluding)

R373.04

Deposit

R373.04

R. (continue)

Item No

7. RUSTDENE HALL / YELLOW HALL / MERWEVILLE / KWA MANDLENKOSI: FEES: (from 1 July 2024)

	Tariff
(a) Concert (Professional Players)	R952.81
Concert (Evening)	R375.28
Concert (Day)	R83.15
(b) Public Auctions: Inside	R375.28
Public Auctions Outdoors	R83.15
(c) Presentations Workshops, Training per hour.	R83.15
(d) Church Services / Funerals: per Hour	R83.15
(e) Games nights (Church & Charity)	R202.25
Games nights (Day)	R133.71
(f) Exhibitions (Evening)	R202.25
Exhibitions (Day)	R141.73
(g) Local School Functions (Evening)	R328.09
Local School Functions (Day)	R238.20
(h) Wedding Receptions (Day)	R375.28
Wedding Receptions (Evening)	R669.67
(i) Product sales: Bazaars	R268.54
(j) Elections	R719.10
(k) Congress	R492.14
(l) Public / Political Meetings	R375.28
(m) Registered Spots and Community Organization Meetings (Day)	R83.15
Registered Sports and Community Organization Meetings (Evening)	R104.49
(n) Song Performance (Evening)	R328.09
Song Performance (Day)	R238.20
(o) Cinema screenings-Evenings (including afternoon screenings) and subject to the conditions set out in Appendix "C"	
(a) Local Schools and Churches and Charities	R202.25
(b) Other Local Institutions	R375.28
(c) Outside Persons	R776.41

(142nd Amendment June 2024)

R. (continue)

Item No

(p)	Dance parties: Organized by non-Beaufort West residents	R937.08
(q)	Dance parties: Organized by people living in Beaufort West	R776.41
(r)	Dance parties: Churches, School, Charities	R492.14
(s)	Bodybuilding, Dance Exercises, Educational Purposes (Including Ballet):	
	Day	R53.93
	Evening	R60.67
(t)	Indoor Sports Exercises:	
	Day	R83.15
	Evening	R98.88
(u)	Indoor Sport Events:	
	Day	R107.87
	Evening	R156.18
(v)	Dinees:	
	Day	R269.66
	Evening	R375.28
(w)	Meals / Birthday Parties:	
	Day	R202.25
	Evening	R328.09
(x)	Banquet section additional	R107.87
(y)	S.A. Post Office Ltd: Payment of pensions (All Pay)	R392.14
(y)(1)	S.A. Post Office Ltd: Payment of pension (All Pay): Nelspoort	R392.14
(z)	Deposit: Refundable	R392.14

(Council: 21 May 2024)

(aa) That Councilors may use halls free of charge for community meetings

(bb) That political parties must pay for use of halls

(Standing Committee: Communities, Emergency Service, etc.: 06 June 2002: Item 2)

(cc) That organizations that use the halls of the Council for a period of four (4) days continuously will only be assessed for three (3) days and one (1) day will be made available free of charge by the Council to the Organization.

That hall be made available to organizations in accordance with current policies and rates on Fridays, Saturdays, and Sundays.

(Standing Committee: Admin.: June 3, 2003: Item 11)

(142nd Amendment: June 2024)

Item No

R. (Continue)

THUSONG CENTRE

Conference hall: Thusong Centre	R521.35
Conference Room Plus Kitchen	R669.67
Kitchen	R179.78
Deposit: Same as Rustdene / Kwa-Mandlenkosi	R392.14

S.

Item No

1. SALE: RENTAL OF
(See Separate-Sale: Item 7)

Hall: Sport Centre

R447.19

(Council: 21 May 2024)

Hall: Mimosa Library

(See B.6)

- (a) That an organization uses the hall of the Council for a period of four (4) days continuously will only be assessed for three (3) days and one (1) day will be made available free of charge by the Council to the organization.
- (b) That halls be made available to organizations in accordance with current policies and rates on Fridays and Saturdays and Sundays.

(Standing Committee: Admin ea.: June 3, 2003: Item 11)

SANITARY SERVICE

(From 1 July 2024)

(1) NIGHT DIRTY REMOVAL: VAT EXCLUDED

- (b) That fees payable to the Council for the removal of night dirt from all premises are as follow:

Two removals per week: R1 832.74 per bucket per year

Three removals per week: R2 752.82 per bucket per year

The minimum removal of night dirt is twice a week

- (c) Where special or irregular removal of night dirt is undertaken from any premises, an amount of: R319.06 per bucket per removal is payable.

- (d) Merweville: Two removals per week per bucket: R1 767.42p. a
Merweville: After hours: R1 767.42 p. a
Merweville: After hours R 338.20
(Per bucket per removal)

(Council: 21 May 2024)

(142nd Amendment: June 2024)

R. (continue)

Item No

- (2) A. OPERATING WASTE
(From 1 July 2024): (VAT excluded)

The fee payable by the owner or occupier to the Council for the disposal of industrial waste twice a week on days determined by the Council from time to time and placed in a container, standard refuse bin or otherwise under these regulations bound together or packed are as follows:

- (a) A minimum of R1197 per annum for a quantity not exceeding 85 m³. This minimum is payable whether this service is used.
- (b) For additional quantities of industrial waste R1197 for every 85 m³ or part thereof per year.

(Council: 21 May 2024)

- (2) B. GARBAGE WASTE SITE: USED BY KAROO NATIONAL PARK

Delete

(Special Council: 11 June 2003: Item 1)

- (3) HOME GARBAGE: (VAT excluded)
(From 1 July 2024)

Beaufort West

Fees payable for removal of household refuse: for a maximum of 1 removal per week R 1217.79 per refuse container per year with a minimum of R967.00 per year whether the service is used.

Merweville R1 073.37 p. a

Nelspoort R1 073.37 p. a

That rubbish bins be made available to H.O.P houses in Merweville for a contribution of R66.78

- (4) BUSINESS GARBAGE:

Fees payable for removal of Business refuse: R288.85 (excl. VAT) a month for bags once a week.

(Council: 21 May 2024)

(142nd Amendment: June 2024)

S. (continue)

Item No

(4) A. PROPERTIES NOT YET WITHIN THE SEWER NETWORK SYSTEM
See R2.B

(5). TEMPORARY RENTAL RENT: FEES

Movable Polytene Toilets: temporary provision and erection of: - at events etc.

(From 1 July 2024)

Rental of newly acquired polythene removable toilets

First day or part thereof	R120.16 per toilet
And for every day thereafter or part thereof	R98.21 per toilet
If toilets are delivered	R254.19 extra

(Council: 21 May 2024)

(6). SANITRY FACILITIES ON BUILDING SITES

The tariff in respect of flush toilets for employees on building sites has been fixed at one twelfth of the sewerage fee as applicable to single dwellings per flush toilet per month with effect from 1 September 1985.

(Finance Committee: 1985.07.29: Special Resolution)

(142nd Amendment: June 2024)

S. (continue)

Item No

5. CIRCUS ON TOWN LANDS

(See Item D 3.1.1 – Town lands)

6. SKUT

(See appendix attached)

7. SPORT: RUGBY Grounds

(See R.4)

(142nd Amendment June 2024)

SCULLETTER ANNOUNCEMENT 18 OF 1983
From 1 July 2024

ANNEXURE B

Basic rate of composition: 21 May 2024

Pound of animals, one or more, per occasion: R101.00

ANNEXURE C and D

Exceedance on built-up and unbuilt plots/ervens

Horses, cattle, ostriches, and pigs per piece	R17.64
Sheep and goats per piece	R 9.33

ANNEXURE E

Pound fees

Horses, horned cattle, pigs, and ostriches per piece	R34.78
Sheep and goats per piece	R9.33

ANNEXURE F

Maintenance fees

Ostriches per piece per day	R17.42
Horses, horned cattle, pigs per head per day	R17.43
Sheep and goats per piece per day	R9.33

ANNEXURE G

Fees for animals that need to be looked after separately

For each stallion per day	R17.42
For each ostrich per day	R17.42
For each bull per day	R17.42
For each pig per day	R17.42
For each sheep ram, goat ram or other animal taken care of separately, per day	R9.33

(Spec Council: 2000.05.30: Item 4)

(142nd Amendment: June 2024)

S. (continue)

Item No

(6) STREETS: TEAM OF BANNERS

(Expired: See Delegation of forces S.2.3)

8A. STREETS: ENGINE ENTRANCE: (from 1 July 2024)

Actual cost
(min) 50% subsidy
(VAT included)

(Council: 27 June 2007: Item 8.10)

8B. STREETS: TARRED OF SIDE PAVEMENTS AND CAR ACCESSORIES

Works are done at real cost.

Transport and Labor: 20% Administrative Cost
Material: 2% Administrative Cost
VAT excluded

(Special Finance Committee: 1994.03.13: Item 6: Special Resolution)

(142nd Amendment: June 2024)

S. (continue)

Item No

9A. SWIMMING POOLS: TOWN, RUSTDENE, KWA-MANDLENKOSI (Youth Hub): VAT included
(From 1 July 2023)

	Children	Adults
Entrance fees:		
Swimming Tickets	R14.61	R15.73
Season tickets	R113.48	R134.83
Monthly tickets	R54.06	R70.79
Per evening (Schools etc.)		R162.92
Per morning (Schools etc.)		R149.44
Swimming exercises (Schools) – per season		R312.36
Per Swim gala (Council: 21 May 2024)		R113.48

Swimming pools: Town, Rustdene and Kwa-Mandlenkosi (Youth Hub)

Rental rate per season of clubs with lease agreement: -

Swimming club R1960.68

Daily rates of clubs with lease agreement, as well as schools: -

Hourly rate R39.33
Evening rate (20:00 – 22:00) R75.28

Clubs without lease agreement, as well as public: -

Hourly rate R134.83
Evening rate (20:00 – 22:00) R

(Council: 21 May 2024)

Pool rental deposit for specific occasions R448.98

(Council: 21 May 2024)

9B. SWIMMING POOL: NELSPOORT: VAT included
(From 1 July 2024)

	Children	Adults
Entrance fees:		
Swimming tickets	R10.11	R13.48
Season tickets	R64.42	R77.53
Monthly tickets	R35.96	R49.44

(Council: 21 May 2024)

(142nd Amendment: June 2024)

S. (continue)

Item No

10. SPORT GROUNDS: RENTAL OF RUGBY FIELD AND FACILITIES

(See Rugby Field R.4)

11. BRICK MAKER: MERWEVILLE

R85.39 per 1000 brick VAT included

(Council: 21 May 2024)

(142nd Amendment: June 2024)

R.

Item No

1. GARDEN REFUSE: (from 1 July 2024): VAT included

Per load from sidewalks (Beaufort West)	R365.17
--	---------

Per load from sidewalk (Merweville & Nelspoort)	R253.93
--	---------

(Council: 21 May 2024)

2. EQUIPMENT: LOAN OF CHAIRS

2.1 That where chairs, subject to their availability, are lent to private institutions and individuals, the following breakage deposit is charged: -

1 – 50 chairs	R496.63
51 – 100 chairs	R993.26
101 -150 chairs	R1489.89

2.2 That in addition to the deposit, a rent of R9.55 per seat per event is charged.

(Council: 21 May 2024)

2.3 That a contract be drawn up between the tenant and the Council with regards to the rental of chairs and a clause be built in which states that if the tenant damages or loses chairs whose value exceeds the deposit amount, the tenant will be held liable for the outstanding amount.

(Standing Committee: Admin ea.: 15 July 2003: Item 15.3)

(142nd Amendment: June 2024)

V.

Item No

1. LIVESTOCK BEADS / KRALE

Self-erected beads / kale per month R22.47

(Executive Committee: 1998.08.24: Item 2.1.2: Special Resolution)

T. (continue)

Item No

2. TRAFFIC: SERVICE OF SUBSCRIPTIONS ON BEHALF OF OTHER LOCAL AUTHORITIES

The head: Traffic services, recommendation was accepted that summonses in respect of traffic offenses should henceforth be ordered by post to offenders and that if no response is received, the services of other local authorities will be use at the rates charged by the Municipal Association of Cape Town, has been proposed, viz.: -

2.1 Administration of summons: -

R46.00	for personal service
R34.83	for any other acceptable
R25.84	if no service was rendered but information was provided for re-summons
R25.84	where the summons is returned because the person could not be traced.

2.2 Administration of warrant for arrest

R101.12	for service of warrant
R40.45	if warrant returned, not served

(Council: 24 May 2005: Item 8.10.1)

3. CARRIERS

(From 1 July 2024)

That available cargo containers for the interim are rented at: - (VAT included)

3.1	6 m ³	R403.37 per month
3.2	3 m ³	R297.75 per month

(Standing Committee: Public Works, Sewerage and Engineering Service: 1998.09.16: Item 19.1)

(142nd Amendment: June 2024)

W.

Item No

1A. WATER: IRRIGATION WATER: (PK 408/1980): from 1 July 2024

(e) For an erf adjoining Donkin or Birth Street in respect of certain turns of a total of eight hours per week, the sum of R230.34 per year with a reduced amount in proportion to the lengths of turns allotted for subdivisions of such erven.

(f) For an erf adjoining De Villiers, Brand, Blyth, Herman, or Grimbeeck Streets in respect of certain turns of a total of three hours per week, the sum of R230.34 per annum with a reduced amount in ratio to the time lengths of turns allocated for smaller ervens or subdivision of such erven.

(Special Council: 19.06.2001: Item 12.1)

1B. WATER: IRRIGATION OF GARDENS: WATER TRUCK: (from 1 July 2024)

A special service by water truck for irrigating lawns and shrubs after hours and on Saturdays at actual cost-plus applicable administration rate.

(Special Finance Committee: 1994.06.13: Item 6: Special Resolution)

2. WATER: HOUSEHOLD

Availability fees

(See availability Fess Item B.5)

(142nd Amendment: June 2024)

W. (continue)

Item No

3.1 WATER: TARIFF: BEAUFORT WEST

That the tariffs in respect of water supply with bill delivery from 1 July 2024 be determined as follows (**VAT Excluded**).

A minimum levy of R118.36 per month for tenants of sub-economic dwellings and R205.59 per month for all other residential and industrial consumers and the following tariffs in respect of water consumption: -

(a) Credit meters

Table 1 below proves the rates for Credit meters for times of No Restrictions and for 5 Phase of water restrictions.

Tariff	Credit Meter Tariff Code	2023/24 rate	2023/24 Rate
Tariff 1	A	R17.06	R18.08
Tariff 2	B	R19.59	R20.77
Tariff 3	C	R22.34	R23.68

Beaufort West Credit Meter Tariff Codes

Tariff	Consumption	No restriction <20% Water shortage	Phase 1 Restriction savings Goal 0% – 10%	Phase 2 Restriction Saving Goal 10% – 20%	Phase 3 Restriction Saving Goal 20% – 30%	Phase 4 Restriction Saving Goal 30% – 40%	Phase 5 Restriction Saving Goal 40% – 50%
		2023/24	2023/24	2023/24	2023/24	2023/24	2023/24
Tariff 1	0 - 6 kl	A	A	A	A	A	A
Tariff 2	7 - 10 kl			B	B	B	1.2B
Tariff 2	7 - 15 kl	B	B				
Tariff 3	16 - 25 kl	C	1.5B				
Tariff 3	11 - 15 kl			1.5B	2B	2B	2.5B
Tariff 4	16 - 20 kl			2B	3B	3B	3.5B
Tariff 4	26 - 35 kl	1.2B	2B				
Tariff 5	21 - 30 kl			2.85B	3.5B	3.5B	4B
Tariff 5	36 kl +++	1.5B	2.85B				
Tariff 6	31 kl +++			3.5B	4.5B	4.5B	5B
Allowance`					Consumption >15kl = 100%	Consumption >10kl = 200%	Consumption >6kl = 250%

Table 1 – Credit Meter Water Consumption Tariff Code

Table 2 below proves the monetary value of the tariffs as laid out in Table 1. The value is rounded up to the nearest cent.

Beaufort West Credit Meter Rates

Tariff	Consumption	No Restriction	Phase 1 Restriction saving Goal 0% – 10%	Phase 2 Restriction Saving Goal 10% – 20%	Phase 3 Restriction Saving Goal 20% – 30%	Phase 4 Restriction Saving Goal 30% – 40%	Phase 5 Restriction Saving Goal 40% – 50%
		2024/25	2024/25	2024/25	2024/25	2024/25	2024/25
Basic Fees		R205.59	R205.59	R205.59	R205.59	R205.59	R205.59
Tariff 1	0 - 6 kl	R18.08	R18.08	R18.08	R18.08	R18.08	R18.08
Tariff 2	7 - 10 kl			R20.77	R20.77	R20.77	R24.92
Tariff 2	7 - 15 kl	R20.77	R20.77				
Tariff 3	16 - 25 kl	R23.68	R31.14				
Tariff 3	11 - 15 kl			R31.14	R41.53	R41.53	R51.84
Tariff 4	16 - 20 kl			R41.53	R62.30	R62.30	R72.67
Tariff 4	26 - 35 kl	R24.92	R49.53				
Tariff 5	21 - 30 kl			R59.18	R72.67	R72.67	R83.06
Tariff 5	36 kl +++	R31.14	R59.18				
Tariff 6	31 kl +++			R72.67	R93.44	R93.44	R103.82
Allowance					Consumption >15kl = 100%	Consumption >10kl = 200%	Consumption >6kl = 250%

Table 2 – Valid value of credit meter rates.

- (b) Availability fee per month: R205.59
- (c) R88.01 per month where there is not a meter on an erf, but only a standing tap for the use of more than one erf.
- (d) That in cases where there is more than one flat on a plot and the dwelling units are not all provided with a separate meter, an additional basic charge of R205.59 is charged for each dwelling unit on the premises.

(e) Businesses

Table 3 below contains the Business Rates

Beaufort West Business Water Rates

Tariff	No Restriction <20% Water Shortage	Phase 1 Restriction Saving Goal 0% – 10%	Phase 2 Restriction Saving Goal 10% – 20%	Phase 3 Restriction Saving Goal 20% – 30%	Phase 4 Restriction Saving Goal 30% – 40%	Phase 5 Restriction Saving Goal 40% – 50%
	2024/25	2024/25	2024/25	2024/25	2024/25	2024/25
Business Code	C	C	1.5B	2B	2B	2.2B
Business Tariff	R23.68	R23.68	R31.42	R41.53	R41.53	R45.69

Table 3 – Business Water Consumption Rates

(f) Transnet According to Tariff 3: That in the case of the “Railway Barracks” as an interim measure only one basic levy of R205.59 is charged in respect of Transnet, without taxing each individual consumer with a separate basic levy.

(g) **Prepaid water meter**

Table 4 and Table 5 below prove the rates for prepaid meters for times of No Restrictions and for 5 Phase of water restrictions.

Beaufort West Prepaid Rates Codes

Table 4 – Prepaid Meter Water Consumption Rates Codes

Beaufort West Prepaid Meter Tariff Codes

Prepaid Meters	Tariff Code	2024/25 Rate
Tariff 1	B	R18.08
Tariff 2	D	R28.62
Tariff 3	E	R31.01

Tariff	Consumption	No restrictions <20% Water Shortage	Phase 1 Restriction Saving Goal 0% – 10%	Phase 2 Restriction Saving Goal 10% – 20%	Phase 3 Restriction Saving Goal 20% – 30%	Phase 4 Restriction Saving Goal 30% – 40%	Phase 5 Restriction Saving Goal 40% – 50%
		2023/24	2023/24	2023/24	2023/24	2023/24	2023/24
Tariff 1	0 - 6 kl	D	D	D	D	D	D
Tariff 2	7 - 10 kl			E	E	E	1.2E
Tariff 2	7 - 15 kl	E	E				
Tariff 3	16 - 25 kl	E	E				
Tariff 3	11 - 15 kl			E	2B	2B	2.5B
Tariff 4	16 - 20 kl			2B	3B	3B	3.5B
Tariff 4	26 - 35 kl	E	2B				
Tariff 5	21 - 30 kl			2.85B	3.5B	3.5B	4B
Tariff 5	36 kl +++	E	2.85B				
Tariff 6	31 kl +++			3.5B	4.5B	4.5B	5B
Allowance					Consumption >15kl = 100%	Consumption >10kl = 200%	Consumption >6kl = 250%

Beaufort West Prepaid Meter rate

Tariff	Consumption	No Restriction <20% Water Shortage	Phase 1 Restriction Saving Goal 0% – 10%	Phase 2 Restriction Saving Goal 10% – 20%	Phase 3 Restriction Saving Goal 20% – 30%	Phase 4 Restriction Saving Goal 30% – 40%	Phase 5 Restriction Saving Goal 40% – 50%
		2023/24	2023/24	2023/24	2023/24	2023/24	2023/24
Tariff 1	0 - 6 kl	R28.62	R28.62	R28.62	R28.62	R28.62	R27.00
Tariff 2	7 - 10 kl			R29.25	R29.25	R29.25	R35.10
Tariff 2	7 - 15 kl	R31.01	R31.01				
Tariff 3	16 - 25 kl	R31.01	R31.01				
Tariff 3	11 - 15 kl			R31.01	R36.16	R36.16	R45.20
Tariff 4	16 - 20 kl			R54.58	R54.24	R54.24	R63.28
Tariff 4	26 - 35 kl	R31.01	R36.16				
Tariff 5	21 - 30 kl			R51.53	R95.52	R63.28	R72.31
Tariff 5	36 kl +++	R31.01	R48.61				
Tariff 6	31 kl +++			R63.28	R81.36	R81.36	R90.40
Allowance					Consumption >15kl = 100%	Consumption >10kl = 200%	Consumption ^{1''''''} >6kl = 250%

Table 5 – Prepaid Meter Water Consumption Rate

(h) Allowances during times of restrictions:

- 1) If a consumer uses more than 15kl during Phase 3 Restrictions, a surcharge of 100% will be charged on the consumption part of the account.
- 2) If a consumer uses more than 10kl during Phase 4 Restrictions, a surcharge of 200% will be charged on the consumption part of the account.
- 3) If a consumer uses more than 6kl during Phase 4 Restrictions, a surcharge of 250% will be charged on the consumption part of the account.

Restriction application Model

A new model for the application of Water Restrictions has been drawn up in accordance with the guidelines contained in the Provincial Gazette Extraordinary No. 7811 of Monday, August 21, 2017. The model determines the monthly water consumption versus water availability and makes recommendations on which Phase of Restrictions are required.

It is recommended that where consumption is less than availability, the next level of restrictions be adopted by the council within a month and where the availability of water begins to improve over a three-month period, the restriction is relaxed.

The table below proves the table contained in the Proclamation.

Column 1	Column 2	Column 3	Column 4	Column 5
LEVEL OF WATER RESTRICTIONS	TRIGGER POINT	PERCENTAGE TARGET REDUCTION IN POTABLE WATER SUPPLY AND DEMAND	TARGET CONSUMPTION OF POTABLE WATER DEMAND (EXPRESSED IN MEGALITRES PER DAY)	CALCULATED NUMBER OF REMAINING WEEKS OF BULK RAW WATER SUPPLY FOR EACH TOWN OR SETTLEMENT IN THE MUNICIPALITY
Water Conservation Measures	Permanent 100% — 81%	Baseline		
1	80% — 66%	0% — 10%		
2	65% — 51%	10% — 20%		
3	50% — 36%	20% — 30%		
4	35% — 21%	30% — 40%		
5	<20%	40% — 50%		

Table 6 – Proclamation Table

3.1 WATER : TARIFF MERWEVILLE (VAT EXCLUDED)

(a) Credit Meter

(b) Tabel 7 en Tabel 8 below prove the rates for Credit meters for times of No Restrictions and also for 5 Phase of water restrictions.

Tariff	Credit Meter Tariff Code	2023/24 Rate	2024/25 Rate
Tariff 1	A	R9.14	R9.69
Tariff 2	B	R10.06	R10.66
Tariff 3	C	R11.00	R11.66

c) Basic Charge R31.35

Merweville Credit Meter Codes

Tariff	Consumption	No Restriction <20% Water Shortage	Phase 1 Restriction	Phase 2 Restriction	Phase 3 Restriction	Phase 4 Restriction	Phase 5 Restriction
		2024/25	2024/25	2024/25	2024/25	2024/25	2024/25
Tariff 1	0 - 6 kl	A	A	A	A	A	A
Tariff 2	7 - 10 kl			B	B	B	1.2B
Tariff 2	7 - 15 kl	B	B				
Tariff 3	16 - 25 kl	1.2B	1.5B				
Tariff 3	11 - 15 kl			1.5B	2B	2B	2.5B
Tariff 4	16 - 20 kl			2B	3B	3B	3.5B
Tariff 4	26 - 35 kl	1.3B	2B				
Tariff 5	21 - 30 kl			2.85B	3.5B	3.5B	4B
Tariff 5	36 kl +++	1.4B	2.85B				
Tariff 6	31 kl +++			3.5B	4.5B	4.5B	5B
Allowance					Consumption >15kl = 100%	Consumption >10kl = 200%	Consumption >6kl = 250%

Table 7 – Credit Meter Consumption Rates Codes - Merweville

Merweville Credit Meter Rates

Tariff	Consumption	No Restriction	Phase 1 Restriction	Phase 2 Restriction	Phase 3 Restriction	Phase 4 Restriction	Phase 5 Restriction
		2024/25	2024/25	2024/25	2024/25	2024/25	2024/25
Basic Rates		R33.23	R33.23	R33.23	R33.23	R33.23	R33.23
Tariff 1	0 - 6 kl	R9.69	R9.69	R9.69	R9.69	R9.69	R9.69
Tariff 2	7 - 10 kl			R10.66	R10.66	R10.66	R12.79
Tariff 2	7 - 15 kl	R10.66	R10.66				
Tariff 3	16 - 25 kl	R13.46	R16.00				
Tariff 3	11 - 15 kl			R16.00	R21.33	R21.33	R26.65
Tariff 4	16 - 20 kl			R32.19	R32.00	R32.00	R37.32
Tariff 4	26 - 35 kl	R13.86	R21.32				
Tariff 5	21 - 30 kl			R30.39	R37.32	R37.32	R10.85
Tariff 5	36 kl +++	R14.08	R30.39				
Tariff 6	31 kl +++			R37.32	R47.99	R47.99	R53.32
Allowance					Consumption >15kl = 100%	Consumption >10kl = 200%	Consumption >6kl = 250%

Table 8 – Credit Meter Water Consumption Tariff – Merweville

(C) Business tariffs

Tariff	No Restrictions <20% Water Shortage	Phase 1 Restriction Saving Goal 0% – 10%	Phase 2 Restriction Saving Goal 10% – 20%	Phase 3 Restriction Saving Goal 20% – 30%	Phase 4 Restriction Saving Goal 30% – 40%	Phase 5 Restriction Saving Goal 40% – 50%
	2024/25	2024/25	2024/25	2024/25	2024/25	2024/25
Business Codes	C	C	1.5B	2B	2B	2.2B
Business tariff	R11.66	R11.66	R16.22	R21.33	R21.33	R21.33

(d) Prepaid Meters

Table 9 and Table 10 below prove the rates for credit meters of times of No Restrictions and for 5 Phase of water restrictions.

Merweville Prepaid Meter Tariff Codes

Prepaid Meters	Tariff Code	2023/24 Rate	2024/25 Rate
Tariff 1	A	R14.33	R15.19
Tariff 2	B	R16.30	R17.28

Merweville Prepaid Meters Rate Codes

Tariff	Consumption	No Restriction <20% Water Shortage	Phase 1 Restriction	Phase 2 Restriction	Phase 3 Restriction	Phase 4 Restriction	Phase 5 Restriction
		2024/25	2024/25	2024/25	2024/25	2024/25	2024/25
Tariff 1	0 - 6 kl	A	A	A	A	A	A
Tariff 2	7 - 10 kl			B	B	B	1.2B
Tariff 2	7 - 15 kl	B	B				
Tariff 3	16 - 25 kl	1.2B	1.5B				
Tariff 3	11 - 15 kl			1.5B	2B	2B	2.5B
Tariff 4	16 - 20 kl			2B	3B	3B	3.5B
Tariff 4	26 - 35 kl	1.3B	2B				
Tariff 5	21 - 30 kl			2.85B	3.5B	3.5B	4B
Tariff 5	36 kl +++	1.4B	2.85B				
Tariff 6	31 kl +++			3.5B	4.5B	4.5B	5B
Allowance					Consumption >15kl = 100%	Consumption >10kl = 200%	Consumption >6kl = 250%

Table 9 – Prepaid Meter Water Consumption Rate Codes – Merweville

Merweville Prepaid Meter Tariffs

Tariff	Consumption	No Restriction	Phase 1 Restriction	Phase 2 Restriction	Phase 3 Restriction	Phase 4 Restriction	Phase 5 Restriction
		2024/25	2024/25	2024/25	2024/25	2024/25	2024/25
Tariff 1	0 - 6 kl	R15.19	R15.19	R15.19	R15.19	R15.19	R15.19
Tariff 2	7 - 10 kl			R17.28	R17.28	R17.28	R20.72
Tariff 2	7 - 15 kl	R17.28	R17.28				
Tariff 3	16 - 25 kl	R20.72	R25.91				
Tariff 3	11 - 15 kl			R25.91	R34.56	R34.56	R43.18
Tariff 4	16 - 20 kl			R34.56	R51.83	R51.83	R60.45
Tariff 4	26 - 35 kl	R22.47	R34.56				
Tariff 5	21 - 30 kl			R49.23	R60.45	R60.45	R69.08
Tariff 5	36 kl +++	R24.18	R49.23				
Tariff 6	31 kl +++			R60.45	R77.72	R77.72	R86.35
Allowance					Consumption >15kl = 100%	Consumption >10kl = 200%	Consumption >6kl = 250%

Table 10 – Prepaid Meter Water Consumption tariffs – Merweville

WATER: TARIFF NELSPOORT (VAT EXCLUDED)

(a) Credit Meter

Tariff	Credit Meter Tariff Code	2023/24 Rate	2024/245Rate
Tariff 1	A	R9.53	R10.10
Tariff 2	B	R10.78	R11.43
Tariff 3	C	R11.81	R12.52
Tariff 4	D	R12.90	R13.67

Nelspoort CREDIT Meter Codes

Tariff	Consumption	No Restriction <20% Water Shortage	Phase 1 Restriction Saving Goal 0% – 10%	Phase 2 Restriction Saving Goal 10% – 20%	Phase 3 Restriction Saving Goal 20% – 30%	Phase 4 Restriction Saving Goal 30% – 40%	Phase 5 Restriction saving Goal 40% – 50%
		2024/25	2024/25	2024/25	2024/25	2024/25	2024/25
Tariff 1	0 - 6 kl	A	A	A	A	A	A
Tariff 2	7 - 10 kl			B	B	B	1.2B
Tariff 2	7 - 15 kl	B	B				
Tariff 3	16 - 25 kl	C	1.5B				
Tariff 3	11 - 15 kl			1.5B	2B	2B	2.5B
Tariff 4	16 - 20 kl			2B	3B	3B	3.5B
Tariff 4	26 - 35 kl	D	2B				
Tariff 5	21 - 30 kl			2.85B	3.5B	3.5B	4B
Tariff 5	36 kl +++	1.3B	2.85B				
Tariff 6	31 kl +++			3.5B	4.5B	4.5B	5B
Allowance					Consumption >15kl = 100%	Consumption >10kl = 200%	Consumption >6kl = 250%

Nelspoort Credit Meter Tariffs

Tariff	Consumption	No Restriction	Phase 1 Restriction	Phase 2 Restriction	Phase 3 Restriction	Phase 4 Restriction	Phase 5 Restriction
		2024/25	2024/25	2024/25	2024/25	2024/25	2024/25
Basic Tariff		R113.63	R113.63	R113.63	R113.63	R113.63	R113.63
Tariff 1	0 - 6 kl	R10.10	R10.10	R10.10	R10.10	R10.10	R10.10
Tariff 2	7 - 10 kl			R11.43	R11.43	R11.43	R13.71
Tariff 2	7 - 15 kl	R11.43	R11.43				
Tariff 3	16 - 25 kl	R12.52	R17.15				
Tariff 3	11 - 15 kl			17.15	R22.85	R22.85	R28.58
Tariff 4	16 - 20 kl			R22.85	R34.28	R34.28	R340.00
Tariff 4	26 - 35 kl	R13.67	R22.85				
Tariff 5	21 - 30 kl			R32.58	R40.00	R40.00	R45.71
Tariff 5	36 kl +++	R14.86	R32.58				
Tariff 6	31 kl +++			R40.00	R51.43	R51.43	R57.13
Allowance					Consumption >15kl = 100%	Consumption >10kl = 200%	Consumption >6kl = 250%

- (b) Basic Charge R113.69
- (c) Hospital: According to Tariff 3 R 12.52
- (d) Other consumers: Fixed Rate R126.84

(e) Prepaid Meters

Nelspoort Prepaid Meter Tariff Codes

Prepaid Meters	Tariff Code	2023/24 Rate	2024/25 Rate
Tariff 1	A	R14.92	R15.82
Tariff 2	B	R17.10	R18.13
Tariff 3	C	R22.34	R23.68

Nelspoort Prepaid Meter Codes

Tariff	Consumption	No Restriction <20% Water Shortage	Phase 1 Restriction Saving Goal 0% – 10%	Phase 2 Restriction Saving Goal 10% – 20%	Phase 3 Restriction Saving Goal 20% – 30%	Phase 4 Restriction Saving Goal 30% – 40%	Phase 5 Restriction Saving Goal 40% – 50%
		2024/25	2024/25	2024/25	2024/25	2024/25	2024/25
Tariff 1	0 - 6 kl	A	A	A	A	A	A
Tariff 2	7 - 10 kl			B	B	B	1.2B
Tariff 2	7 - 15 kl	B	B				
Tariff 3	16 - 25 kl	C	C				
Tariff 3	11 - 15 kl			1.5B	2B	2B	2.5B
Tariff 4	16 - 20 kl			2B	3B	3B	3.5B
Tariff 4	26 - 35 kl	1.2B	2B				
Tariff 5	21 - 30 kl			2.85B	3.5B	3.5B	4B
Tariff 5	36 kl +++	1.5B	2.85B				
Tariff 6	31 kl +++			3.5B	4.5B	4.5B	5B
Allowance					Consumption >15kl = 100%	Consumption >10kl = 200%	Consumption >6kl = 250%

Nelspoort Prepaid Meter Tariffs

Tariff	Consumption	No Restriction <20% Water Shortage	Phase 1 Restriction Saving Goal 0% – 10%	Phase 2 Restriction Saving Goal 10% – 20%	Phase 3 Restriction Saving Goal 20% – 30%	Phase 4 Restriction Saving Goal 30% – 40%	Phase 5 Restriction Saving Goal 40% – 50%
		2024/25	2024/25	2024/25	2024/25	2024/25	2024/25
Tariff 1	0 - 6 kl	R15.82	R15.82	R15.82	R15.82	R15.82	R15.82
Tariff 2	7 - 10 kl			R18.13	R18.13	R18.13	R21.75
Tariff 2	7 - 15 kl	R27.36	R27.36				
Tariff 3	16 - 25 kl	R23.68	R23.68				
Tariff 3	11 - 15 kl			R27.19	R36.25	R36.25	R45.32
Tariff 4	16 - 20 kl			R36.25	R54.38	R54.38	R63.44
Tariff 5	21 - 30 kl			R51.65	R63.44	R63.44	R72.50
Tariff 5	26 - 35 kl	R21.75	R36.25				
Tariff 5	36 kl +++	R27.19	R51.65				
Tariff 6	31 kl +++			R63.44	R81.57	R81.57	R90.63
Allowance					Consumption >15kl = 100%	Consumption >10kl = 200%	Consumption >6kl = 250%

Water flat rate (VAT excluded)

A flat rate structure for all prepaid water meters will be implemented to levy on municipal accounts of consumers without transaction history, no meters installed and for the period of maintenance of water meters. The tariff shall be levied at the cost applicable 0-6kl rate on the water sliding scale for prepaid water purchases

Beaufort West R 28.62

Nelspoort R 15.82

Merweville R 15.19

(Council: 21 May 2024)

W. (continue)

Item No

2. TOOL RENTAL

7.1 See Annexure attached
(Council: 1998.09.14: Item 7: Special Resolution)

8. WORK: PRIVATE AND DEPARTMENTAL: SERVICE FEE: 1 JULY 1994

Where a tariff has been fixed by ordinance or council decision, this tariff will also apply to interdepartmental work performed.

Where no tariff has been determined, the actual wages apply in respect of departmental works, capital works as well as private work in respect of which a head of expenditure is opened and the following wages calculated on the highest notch of the wage scale (scales) plus the leave bonus apply in respect of other private work.

(142nd Amendment: June 2024)

W. (continue)

Item No

9. WORKSHOP: VEHICLE INVESTIGATION CENTRE

(From 1 July 2024)

Light testing device	R20.22per occasion
Wheel tracking device	R9.55 per occasion
Brake test device	R9.55 per occasion
Axis mass meter	R9.55 per occasion

(Finance Committee: 1991.06.24: Item 29: Special Resolution)

(142nd Amendment: June 2024)

Fire Fighting Tariffs

01 July 2024

10. Tariffs for Delivery of Emergency and Special Services Rendered.

Call Out Fees

Service	2024/2025
Heavy Duty Pump	R450.00
Medium Duty Pump	R280.00
Light Duty Pump	R280.00
Rescue Tender	R280.00
Water Tender	R230.00

Service fees per hour or part thereof:

Service	2024/2025
Heavy Duty Pump	R450.00
Medium Duty Pump	R280.00
Light Duty Pump	R280.00
Rescue Tender	R280.00
Water Tender	R230.00
Officer	R170.00
Fire Fighter	R120.00

Special events

	2024/2025
Service Fee for Attending special events per day or part there off (excluding service fees)	R2200.00

Travelling

Service	2024/2025
Within District Municipal boundaries	R18 per KM

Charges for water usage

Service	2024/2025
	Applicable tariff plus 10%

Consumable Material

Service	2024/2025
Expenses for resources such as fuel, chemical agents, servicing, recharging and / or reconditioning of fire equipment, etc	Replacement / repair Cost plus 20%
Any other bona fide expenses incurred by the Council as result of such services rendered, including staff rehabilitation (Counselling), rental of specialized equipment, additional legal expenses, and all liabilities, obligations, losses, damages, penalties, fines, claims (whether fraudulent, groundless, false or not), demands, actions, suits, judgements, legal proceedings (whether civil or criminal), investigations, costs, disbursements and expenses (including legal fees and etc	Cost plus 20%
Fire Fighting Foam	Replace stock with same type and quantity rounded to the highest 25 litre, or cost-plus 20%

Inspections (Charged per hour or part thereof)

	2024/2025
General requested inspections	R250.00
Fire Works Display and Storage	R255.00
Compliance Certificates	R255.00

- 10.1 A callout is calculated as a minimum of one hour or part thereof.
- 10.1.1 More than 30 minutes shall be calculated as one hour while less than 30 minutes shall be calculated as half an hour.
 - 10.1.2 The time shall be calculated from turnout point to return to base.
 - 10.1.3 Tariffs for extrication/rescue services shall be applicable and calculated for each patient/victim extricated.
 - 10.1.4 Auxiliary services will only be rendered on the acceptance of a written quotation.
 - 10.1.5 In the case of road traffic accidents, the department will first endeavour to recover the tariffs from the Road
 - 10.1.6 Accident Fund, where after it will be the responsibility of the patient/victim.
 - 10.1.7 Certificate of Acceptability for Fire Safety issued in terms of the Fire Brigade Services Act, Act 99 of 1987 and the "Standard Community Fire Safety By-Law" Provincial Notice 342/200 (P/M 342-2006) 27 Oct 2006 Gazette 6389.
- 10.2 That the undermentioned protocols be excluded or exempted from the tariffs and for the or Chief: Fire Services / Superintendent: Fire Services: -
- 10.2.1 When a false alarm has been received but the responsible person, in the opinion of the Chief Fire Officer, acted in good faith, no charges shall be applicable.
 - 10.2.2 Council withholds the right to revoke all charges relating to: - Civil Commotion - Riots - Natural Disasters - Either locally or on request of another sphere of Government.
 - 10.2.3 No charges shall be applicable to any registered indigents.
 - 10.2.4 Bona fide charitable organizations may be exempted from any charges.
 - 10.2.5 Should new training courses be developed the Head of Community Safety be allowed to implement an appropriate interim tariff until the next financial year.
 - 10.2.6 Exercises, where such exercises are requested and initiated by the Beaufort West municipality Fire Services.
 - 10.2.7 International assistance rendered on request of the National Sphere of Government.
 - 10.2.8 Where Council is the sole beneficiary of services rendered, provided that the requesting department may be held liable for overtime costs and additional expenses incurred.

(142nd Amendment: June 2024)